

aicdesign presents

CMOS Analog Integrated Circuit Design

May 22-26, 2006

Hampton Inn & Suites

Amelia Island, Florida

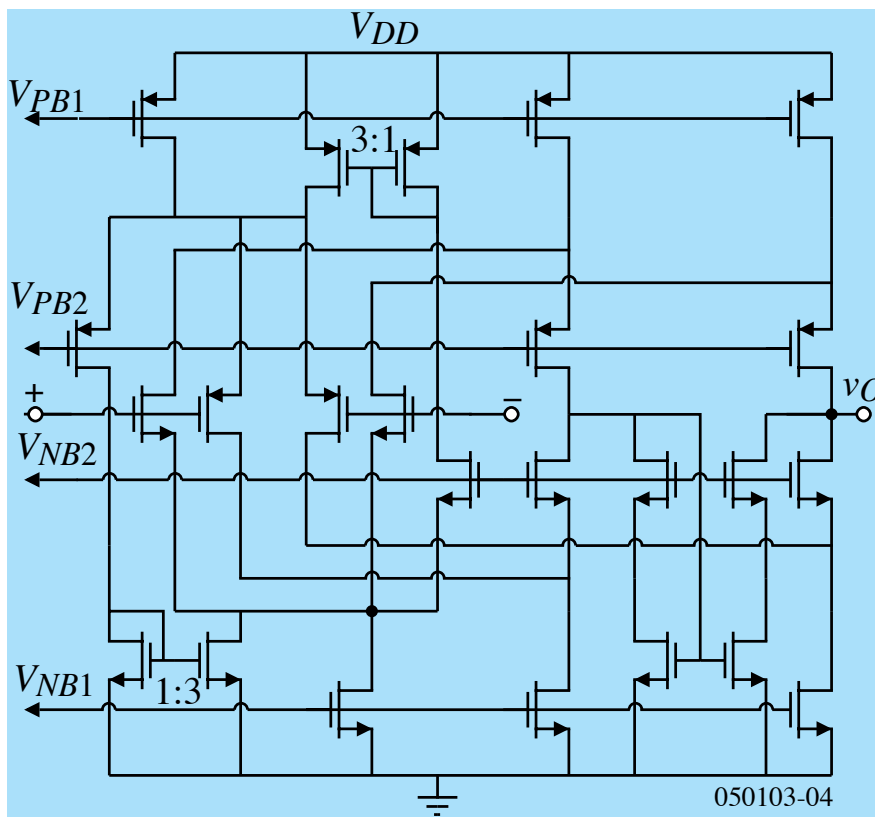

Organized and Presented by
Prof. Phillip E. Allen
P.O. Box 15008
Fernandina Beach, FL 32035

www.aicdesign.org

Who Should Attend

This course has been designed for circuit designers who need to implement analog integrated circuits using CMOS technologies. The course will provide experienced analog circuit designers with a valuable update on the latest and upcoming developments in the field. It will give novices, and those considering entering the field, an indispensable foundation in the fundamentals of the technology, and ways in which it can be implemented successfully. Participants should have a general knowledge of analog circuits, electrical circuit analysis, and familiarity with integrated circuit technology.

Participants' Comments

"the course content and support documentation was very good"

"detailed circuit analysis"

"Prof. Allen has an excellent way of presenting the course material"

"excellent coverage of a huge subject in short time. An excellent 12 week course neatly fitted into 5 days"

"informative, enjoyable, full of insights... I learned a lot!"

"highly recommended for experienced and new engineers requiring an improvement in analog design"

"several new design ideas which I as a bipolar designer, found very useful..."

"an excellent choice of course for an excellent choice of career"

"Best feature of the course is the explanations of the concepts required for analog design without all the equations"

" I am now far more confident of success with my analog CMOS designs"

Course Description

This course has been designed:

- To provide a state-of-the-art review of the principles, concepts, and techniques needed to carry out the successful design of CMOS analog integrated circuits.
- To expose the participants to the methods used in the processing and design of such circuits, including electrical modeling, characterization of the process parameters, SPICE simulation techniques, testability considerations, and methods of experimental verification.
- To combine an academic viewpoint with practical examples and industry experience.

What is the Course About?

The course provides a bottom-up, hierarchical approach to the subject of analog circuit and systems design using standard CMOS technologies. Simple modeling techniques are used to gain an understanding of and insight into the function of circuits. Computer simulation is used to predict circuit performance. Techniques suitable to enhanced performance using integrated circuit technology are used. In addition, the implications of IC fabrication are used whenever possible to associate the electrical performance with the physical attributes of the circuit.

Course Description

Introduction to Technology

- Basic MOS Semiconductor Fabrication Processes
- PN Junction
- MOS Transistor
- CMOS Transistors
- BJT Transistors
- Passive Components
- Other Technology Considerations

Analog Circuit Modeling

- Simple MOS Large Signal Model
- Modifications for Submicron Technology
- Small-signal MOS Model
- BJT Large-signal Model
- BJT Small-signal Model
- Computer Models
- Extraction of Simple Model using the Computer

Analog Subcircuits

- The MOS Switch
- MOS Diode
- MOS and Bipolar Current Source/Sinks
- Current Mirrors
- Current and Voltage References
- Bandgap Voltage References

Amplifiers

- Simple Inverters
- Differential Amplifiers
- Cascode Amplifiers
- Current Amplifiers
- Output Amplifiers
- High Gain Architectures

Operational Transconductance Amplifiers

- General Design Principles of Op Amps
- Compensation of OTA's
- Two-stage CMOS OTA Design
- Power Supply Rejection Ratio of the Two-Stage Op Amp
- Cascode Op Amps
- Simulation and Measurement Techniques
- Macromodels for Op Amps

High Performance Op Amps

- Buffered Amplifiers
- High-Speed/Frequency Op Amps
- Differential Output Op Amps
- Micropower Op Amps
- Low Noise Op Amps
- Low Power Supply Op Amps

Comparators

- Characterization of Comparators
- Two-stage Open-loop Comparator
- Other Open-loop Comparators
- Improving the Performance of Open-loop Comparators
- Discrete-time comparators
- High-speed comparators

Digital-Analog & Analog-Digital Converters

- Characterization and Definition of D/A and A/D Converters
- Current Scaling D/A Converters
- Voltage Scaling D/A Converters
- Charge Scaling D/A Converters
- Voltage and Charge Scaling D/A Converters
- Other Types of D/A Converters
- Characterization and Definition of A/D Converters
- Serial A/D Converters
- Medium-Speed A/D Converters
- High-Speed A/D Converters
- Oversampled A/D Converters
- State of the Art A/D Converters, Limits of A/D Converters

For questions regarding course content, contact Dr. Phillip Allen via e-mail at pallen@ece.gatech.edu or by phone at 9004-491-1093

Course Instructor

The course will be presented by Dr. Phillip Allen, who is Professor Emeritus at Georgia Institute of Technology in Atlanta, GA, USA. Dr. Allen has over 40 years of experience in teaching and research of analog integrated circuits. He is a registered electrical engineer in the state of California and is a Life Fellow of the IEEE. He is widely regarded as one of the foremost international authorities on analog CMOS circuit design. He has worked and consulted with many companies, including Lawrence Livermore Laboratory, General Motors (Delco), Pacific Missile Range, Texas Instruments, Lockheed Research Laboratory, and National Semiconductor. Dr. Allen has taught at the University of California (Santa Barbara), Texas A&M University, and Georgia Tech. He is the co-author of "Introduction to Theory and Design of Active Filters" (1980), "Switched Capacitor Circuits" (1984), "CMOS Analog Circuit Design" (1987), and "VLSI Techniques for Analog and Digital Circuits" (1990). He teaches short courses on CMOS analog circuit design in Europe, Asia and the USA on a regular basis.

Registration

Register by:

Mail:

CMOS Analog Circuit Design
P.O. Box 15008
Fernandina Beach, FL 32035

Web:

www.aicdesign.org

After you register, you will receive your confirmation letter with detailed instructions.

AICDesign reserves the right to cancel a course for any reason, including insufficient enrollment. If a course is cancelled, all registration fees will be refunded.

Course Fee

The course fee of \$1,695 includes all necessary classroom materials (lecture notes and copy of "CMOS Analog Circuit Design", second edition). Checks can be made payable to CMOS Analog Circuit Design, or charges to VISA, MasterCard, American Express or Discover cards can be made through registration at www.aicdesign.org.

You are encouraged to register early to ensure your place in the course. Please remit payment no later than 10 days prior to the course start date. Advance payment arrangements are required to guarantee your place in the class.

Course Location and Accommodations

The May 2006 offering will be held at the Hampton Inn & Suites, located at 19 South Second Street, Fernandina Beach, Florida 32034, USA. This hotel is located in the historic downtown district on Amelia Island. A block of rooms has been reserved for program registrants, but will be released two weeks prior to the program at Hampton Inn & Suites. Mention that you are attending the CMOS Analog Integrated Circuit Design short course for a special room rate (the group code is EEC). For hotel reservations, call 1-800-HAMPTON or go to www.hamptoninnandsuites.net.

Amelia Island is a 38 minute drive northeast of Jacksonville International Airport. Transportation between Jacksonville International Airport and Amelia Island is available at the airport. By automobile leave the airport on Dixie Clipper Rd. which becomes FL-102E. After 1.6 miles, merge north onto I-95N. After 9 miles on I-95N take the SR-A1A exit (Exit 373) and proceed east toward Yulee/Amelia Island. After 14.2 miles on SR-A1A/ SR-200, turn left onto Ash Street. Go 0.3 miles and turn right onto South Second St. The Hampton Inn and Suites is located at 19 South Second Street.

Course Times and Schedule

The daily schedule for the course is:

08:30	Session I
10:00	Morning Break
10:15	Session II
11:45	Lunch (not provided but there are many restaurants nearby)
01:15	Session III
02:45	Afternoon Break
03:00	Session IV
04:30	Day ends (Friday the day ends at 03:00)

Cancellations and Refunds

To cancel your registration and receive a full refund, you must call (404) 603-9374 at least 10 business days prior to the course start date or send an e-mail to pallen@ece.gatech.edu. A cancellation received fewer than 10 days prior to the start date will be refunded the registration amount, less \$100 to cover the costs of the materials and facilities. If you do not call or send an e-mail to cancel your registration and do not attend the course you are still responsible for the full fee.

Other Courses

Other courses in analog design are available from aicdesign.org. These courses include Phase-Lock Loops, Switched Capacitor Circuits, and the Practice of Analog IC Design (in 2006).

AICDesign Short Courses
P.O. Box 15008
Fernandina Beach, FL 32035

CMOS Analog Integrated Circuit Design

May 22-26, 2006, Amelia Island, Florida

REGISTRATION FORM

CMOS Analog Intergrated Circuit Design May 22-26, 2006 Course Fee \$1695

Please remit payment no later than 10 days prior to the course start date. Send to:

AICDesign, P.O. Box 15008, Fernandina Beach, FL 32035

I cannot attend this program, but add me to your mailing list.

PLEASE PRINT CLEARLY

Name: _____

Position: _____ Organization: _____

Address: _____

City: _____ State: _____ ZIP: _____

Daytime Phone Number: _____ FAX Number: _____

E-mail: _____

PAYMENT OPTIONS

Check in the amount of \$1695 per attendee, made payable to **CMOS Analog Integrated Circuits Course**
(Please include attendee's name and course date on all checks.)

Credit card payments can only be made through web registration (www.aicdesign.org)

I heard about this course by: brochure web e-mail fax co-worker regular mail other