

AICDesign presents

# CMOS Analog Integrated Circuit Design

March 27-31, 2006  
Biltmore Hotel & Suites  
Santa Clara, California

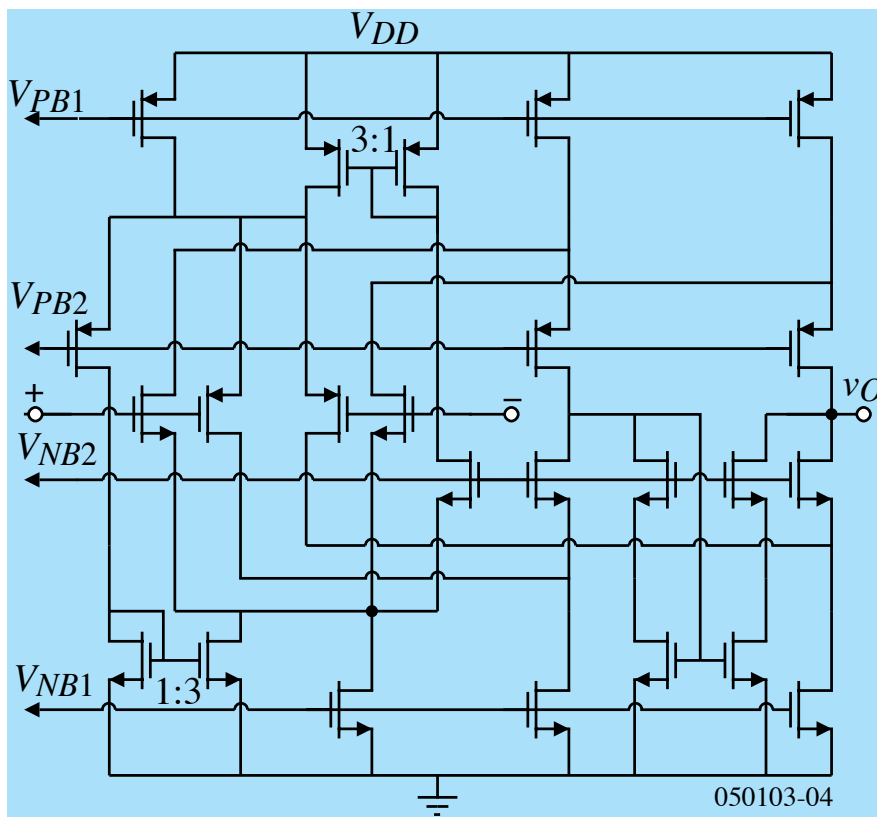

Organized and Presented by  
Dr. Phillip E. Allen  
P.O. Box 15008  
Fernandina Beach, FL 32035

[www.aicdesign.org](http://www.aicdesign.org)

## Who Should Attend

This course has been designed for circuit designers who need to implement analog integrated circuits using CMOS technologies. The course will provide experienced analog circuit designers with a valuable update on the latest and upcoming developments in the field. It will give novices, and those considering entering the field, an indispensable foundation in the fundamentals of the technology, and ways in which it can be implemented successfully. Participants should have a general knowledge of analog circuits, electrical circuit analysis, and familiarity with integrated circuit technology.

## Participants' Comments

"the course content and support documentation was very good"

"detailed circuit analysis"

"Prof. Allen has an excellent way of presenting the course material"

"excellent coverage of a huge subject in short time. An excellent 12 week course neatly fitted into 5 days"

"informative, enjoyable, full of insights... I learned a lot!"

"highly recommended for experienced and new engineers requiring an improvement in analog design"

"several new design ideas which I as a bipolar designer, found very useful..."

"an excellent choice of course for an excellent choice of career"

"Best feature of the course is the explanations of the concepts required for analog design without all the equations"

" I am now far more confident of success with my analog CMOS designs"

## Course Description

This course has been designed:

- To provide a state-of-the-art review of the principles, concepts, and techniques needed to carry out the successful design of CMOS analog integrated circuits.
- To expose the participants to the methods used in the processing and design of such circuits, including electrical modeling, characterization of the process parameters SPICE simulation techniques, testability considerations, and methods of experimental verification.
- To combine an academic viewpoint with practical examples and industry experience.

## What is the Course About?

The course provides a bottom-up, hierarchical approach to the subject of analog circuit and systems design using standard CMOS technologies. Simple modeling techniques are used to gain an understanding of and insight into the function of circuits. Computer simulation is used to predict circuit performance. Techniques suitable to enhanced performance using integrated circuit technology are used. In addition, the implications of IC fabrication are used whenever possible to associate the electrical performance with the physical attributes of the circuit.

## Course Description

### Introduction to Technology

- Basic MOS Semiconductor Fabrication Processes
- PN Junction
- MOS Transistor
- CMOS Transistors
- BJT Transistors
- Passive Components
- Other Technology Considerations

### Analog Circuit Modeling

- Simple MOS Large Signal Model
- Modifications for Submicron Technology
- Small-signal MOS Model
- BJT Large-signal Model
- BJT Small-signal Model
- Computer Models
- Extraction of Simple Model using the Computer

### Analog Subcircuits

- The MOS Switch
- MOS Diode
- MOS and Bipolar Current Source/Sinks
- Current Mirrors
- Current and Voltage References
- Bandgap Voltage References

### Amplifiers

- Simple Inverters
- Differential Amplifiers
- Cascode Amplifiers
- Current Amplifiers
- Output Amplifiers
- High Gain Architectures

### Operational Transconductance Amplifiers

- General Design Principles of Op Amps
- Compensation of OTA's
- Two-stage CMOS OTA Design
- Power Supply Rejection Ratio of the Two-Stage Op Amp
- Cascode Op Amps
- Simulation and Measurement Techniques
- Macromodels for Op Amps

### High Performance Op Amps

- Buffered Amplifiers
- High-Speed/Frequency Op Amps
- Differential Output Op Amps
- Micropower Op Amps
- Low Noise Op Amps
- Low Power Supply Op Amps

### Comparators

- Characterization of Comparators
- Two-stage Open-loop Comparator
- Other Open-loop Comparators
- Improving the Performance of Open-loop Comparators
- Discrete-time comparators
- High-speed comparators

### Digital-Analog & Analog-Digital Converters

- Characterization and Definition of D/A and A/D Converters
- Current Scaling D/A Converters
- Voltage Scaling D/A Converters
- Charge Scaling D/A Converters
- Voltage and Charge Scaling D/A Converters
- Other Types of D/A Converters
- Characterization and Definition of A/D Converters
- Serial A/D Converters
- Medium-Speed A/D Converters
- High-Speed A/D Converters
- Oversampled A/D Converters
- State of the Art A/D Converters, Limits of A/D • Converters

For questions regarding course content, contact Dr. Phillip Allen via e-mail at [pallen@ece.gatech.edu](mailto:pallen@ece.gatech.edu) or by phone at 904-491-1093

## Course Instructor

The course will be presented by Dr. Phillip Allen, who is Professor Emeritus at Georgia Institute of Technology in Atlanta, GA, USA. Dr. Allen has over 40 years of experience in teaching and research of analog integrated circuits. He is a registered electrical engineer in the state of California and is a Life Fellow of the IEEE. He is widely regarded as one of the foremost international authorities on analog CMOS circuit design. He has worked and consulted with many companies, including Lawrence Livermore Laboratory, General Motors (Delco), Pacific Missile Range, Texas Instruments, Lockheed Research Laboratory, and National Semiconductor. Dr. Allen has taught at the University of California (Santa Barbara), Texas A&M University, and Georgia Tech. He is the co-author of "Introduction to Theory and Design of Active Filters" (1980), "Switched Capacitor Circuits" (1984), "CMOS Analog Circuit Design" (1987), and "VLSI Techniques for Analog and Digital Circuits" (1990). He teaches short courses on CMOS analog circuit design in Europe, Asia and the USA on a regular basis.

## Registration

Register by:

Mail:

CMOS Analog Circuit Design  
P.O. Box 15008  
Fernandina Beach, FL 32035

Web:

[www.aicdesign.org](http://www.aicdesign.org)

After you register, you will receive your confirmation letter with detailed instructions.

AICDesign reserves the right to cancel a course for any reason, including insufficient enrollment. If a course is cancelled, all registration fees will be refunded.

## Course Fee

The course fee of \$1,695 includes all necessary classroom materials (lecture notes and copy of "CMOS Analog Circuit Design", second edition). Checks can be made payable to CMOS Analog Circuit Design, or charges to VISA, MasterCard, American Express or Discover cards can be made through registration at [www.aicdesign.org](http://www.aicdesign.org).

You are encouraged to register early to ensure your place in the course. Please remit payment no later than 10 days prior to the course start date. Advance payment arrangements are required to guarantee your place in the class.

## Course Location and Accommodations

The course will be held at the Biltmore Hotel and Suites located at 2151 Laurelwood Drive, Santa Clara, CA 95954. The hotel is conveniently located in Silicon Valley and is at the intersection of Highway 101 and San Tomas/Montague Expressway. A block of rooms has been reserved for program registrants, but will be released two weeks prior to the program at the Biltmore Hotel and Suites. Mention that you are attending the CMOS Analog Integrated Circuit Design short course for a special room rate. For hotel reservations, call 1-800-255-9925 or go to [www.hotelbiltmore.com](http://www.hotelbiltmore.com).

The hotel is located within several miles of the San Jose Airport and the Biltmore Hotel operates a shuttle service to and from the airport. To get to the hotel by car from San Jose Airport, get on US-101 north toward San Francisco, go 2.2 miles and take the San Tomas /Montague Expressway exit. The Biltmore Hotel & Suites will be on your right as you exit.

To get to the hotel from the San Francisco International Airport, take US-101 south toward San Jose as you leave the airport. After 30 miles take the San Tomas/Montague Expressway exit. Take the Montague Expressway ramp and circle around crossing over US-101. The Biltmore Hotel & Suites will be on the right as you cross US-101.

## Course Times and Schedule

The daily schedule for the course is:

08:30	Session I
10:00	Morning Break
10:15	Session II
11:45	Lunch (not provided but there are many restaurants nearby)
01:15	Session III
02:45	Afternoon Break
03:00	Session IV
04:30	Day ends (Friday the day ends at 03:00)

## Cancellations and Refunds

To cancel your registration and receive a full refund, you must call (904) 491-1093 at least 10 business days prior to the course start date or send an e-mail to [pollen@ece.gatech.edu](mailto:pollen@ece.gatech.edu). A cancellation received fewer than 10 days prior to the start date will be refunded the registration amount, less \$100 to cover the costs of the materials and facilities. If you do not call or send an e-mail to cancel your registration and do not attend the course you are still responsible for the full fee.

## Other Courses

Other courses in analog design are available from AICDesign. These courses include Phase-Lock Loops, Switched Capacitor Circuits, and the Practice of Analog IC Design (starting in 2007).

AICDesign Short Courses  
P.O. Box 15008  
Fernandina Beach, FL 32035

# CMOS Analog Integrated Circuit Design

March 27-31, 2006, Santa Clara, California

---

## REGISTRATION FORM

**CMOS Analog Intergrated Circuit Design    March 27-31, 2006    Course Fee \$1695**

Please remit payment no later than 10 days prior to the course start date. Send to:

**AICDesign, P.O. Box 15008, Fernandina Beach, FL 32035**

I cannot attend this program, but add me to your mailing list.

### PLEASE PRINT CLEARLY

Name: \_\_\_\_\_

Position: \_\_\_\_\_ Organization: \_\_\_\_\_

Address: \_\_\_\_\_

City: \_\_\_\_\_ State: \_\_\_\_\_ ZIP: \_\_\_\_\_

Daytime Phone Number: \_\_\_\_\_ FAX Number: \_\_\_\_\_

E-mail: \_\_\_\_\_

### PAYMENT OPTIONS

Check in the amount of \$1695 per attendee, made payable to **CMOS Analog Integrated Circuits Course**  
(Please include attendee's name and course date on all checks.)

Credit card payments can only be made through web registration ([www.aicdesign.org](http://www.aicdesign.org))

I heard about this course by:  brochure  web  e-mail  fax  co-worker  regular mail  other