

LECTURE 060 –PLL DESIGN EQUATIONS AND MEASUREMENTS

INTRODUCTION

Objective

The objective of this presentation is

- 1.) To provide a summary of relationships and equations that can be used to design PLLs.
- 2.) Illustrate the design of a DPLL frequency synthesizer
- 3.) Show how to make measurements on PLLs

Outline

- PLL design equations
- PLL design example
- PLL measurements
- Summary

PLL DESIGN EQUATIONS

Introduction

The following design equations are to be used in designing PLLs and apply both to LPLLs and DPLLs with the following definitions:

LPLLs: $N = 1$ and $\beta = 1$

where N is the divider in the feedback loop and β is the loop *expansion factor* determined by the type of PFD.

$$\text{Loop gain} = K_v = \frac{K_d K_o F(0)}{N}$$

Goal of these equations:

Permit the basic design of an LPLL or DPLL.

Type – I, First-Order Loop ($F(0) = 1$)

Crossover frequency (frequency at which the loop gain is 1 or 0dB):

$$\omega_c = K_v \text{ (radians/sec.)}$$

-3dB Bandwidth (frequency at which the closed-loop gain is equal to -3dB):

$$\text{Closed loop transfer function} = \frac{K_v}{s + K_v} \rightarrow \omega_{-3\text{dB}} = K_v \text{ (radians/sec.)}$$

Noise Bandwidth:

$$B_n = \int_0^{\infty} |H(j2\pi f)|^2 df = \int_0^{\infty} \frac{K_v^2}{K_v^2 + (2\pi f)^2} df = \frac{K_v}{2\pi} \int_0^{\infty} \frac{K_v}{K_v^2 + (2\pi f)^2} d(2\pi f) = \frac{K_v \pi}{2\pi \cdot 2} = \frac{K_v}{4} \text{ (Hz)}$$

Hold Range:

$$\Delta\omega_H = \beta N K_v$$

Lock (Capture) Range:

$$\Delta\omega_L = \Delta\omega_H = \beta N K_v$$

Type-I, First-Order Loop ($F(0) = 1$) - Continued

Steady-State Phase Error:

$$\text{For a sinusoidal phase detector, } \epsilon_{ss} = \lim_{t \rightarrow \infty} \theta(t) = \sin^{-1} \left(\frac{\Delta\omega_{osc}}{N K_v} \right)$$

$$\text{For a nonsinusoidal (digital) phase detector, } \epsilon_{ss} = \lim_{t \rightarrow \infty} \theta(t) = \frac{\Delta\omega_{osc}}{N K_v} \leq \beta$$

The steady-state error is never larger than β . A larger error indicates a failure to lock.

Frequency Acquisition Time:

$$T_a = \frac{1}{K_v} \text{ (sec.)}$$

For a Type-I loop,

Lock Range and Acquisition Time = Hold Range and Acquisition Time.

Type-I, Second-Order Loop

This type of loop is generally implemented with a lag-lead filter as shown below.

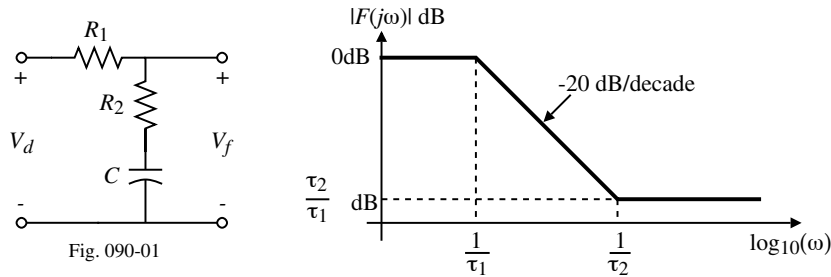

Fig. 090-01

Filter Transfer Function:

$$F(s) = \frac{1 + \tau_2 s}{1 + \tau_1 s} \quad \text{where } \tau_1 = (R_1 + R_2)C \quad \text{and} \quad \tau_2 = R_2 C$$

(Note: The definition for $\tau_1 = (R_1 + R_2)C$ which is different from that in Lecture 050)

System Parameters:

$$\omega_n = \sqrt{\frac{K_o K_d}{\tau_1}} = \sqrt{\frac{K_v}{\tau_1}} \quad \text{and} \quad \xi = \frac{\omega_n}{2} \left(\tau_2 + \frac{1}{K_o K_d} \right) = \frac{1}{2} \sqrt{\frac{1}{K_v \tau_1} (1 + \tau_2 K_v)}$$

Note that because $\tau_2 < \tau_1$, we see that

$$\frac{\omega_n}{2K_v} < \xi < \frac{K_v^2 + \omega_n^2}{2\omega_n K_v}$$

Type-I, Second-Order Loop – Continued

Crossover Frequency:

The general close-loop frequency response for high-gain loops is,

$$H(s) = \frac{2s\xi\omega_n + \omega_n^2}{s^2 + 2\xi\omega_n s + \omega_n^2} = \frac{1}{1 + \frac{s^2}{2\xi\omega_n s + \omega_n^2}} = \frac{1}{1 + \text{Loop Gain}}$$

The crossover frequency, ω_c , is the frequency when the loop gain is unity.

$$\therefore \frac{\omega_c^4}{\omega_n^4 + 4\xi^2 \omega_n^2 \omega_c^2} = 1 \quad \rightarrow \quad \omega_c^4 - (4\xi^2 \omega_n^2) \omega_c^2 - \omega_n^4 = 0$$

Solving for ω_c gives,

$$\omega_c = \omega_n \sqrt{2\xi^2 + \sqrt{4\xi^4 + 1}}$$

3dB Bandwidth:

$$\omega_{-3dB} = \omega_n \sqrt{b + \sqrt{b^2 + 1}} \quad \text{where } b = 2\xi^2 + 1 - \frac{\omega_n}{K_v} \left(4\xi - \frac{\omega_n}{K_v} \right)$$

Noise Bandwidth:

$$B_n = \frac{\omega_n}{2} \left(\xi + \frac{1}{4\xi} \right) \quad (\text{Hz})$$

Type-I, Second-Order Loop – Continued

Hold Range:

$$\Delta\omega_H = \beta NK_v$$

Lock Range:

$$\Delta\omega_L = \frac{\tau_2}{\tau_1} \Delta\omega_H = \frac{\tau_2}{\tau_1} \beta NK_v$$

Lock Time:

The lock time is set by the loop natural frequency, ω_n and is

$$T_L = \frac{2\pi}{\omega_n}$$

Pull-in Range:

$$\Delta\omega_P = N\beta\sqrt{2}\sqrt{2\xi\omega_n K_v F(0) - \omega_n^2}$$

This formula is only valid for moderate or high loop gains, i.e. $K_v F(0) \leq 0.4\omega_n$.

Pull-in Time:

$$T_P \approx \frac{4\left(\frac{\Delta f_{osc}}{N}\right)^2}{B_n^3} \approx \frac{\pi^2}{16} \frac{\Delta\omega_{osc}^2}{\xi\omega_n^3}$$

Note that $\Delta\omega_H \leq \Delta\omega_{osc} \leq \Delta\omega_P$ **Type-I, Second-Order Loop – Continued**

Frequency Acquisition Time:

$$T_a = T_P + T_L$$

If the frequency step is within the lock limit (one beat), then the pull-in time is zero.

Steady-State Phase Error to a frequency step of $\Delta\omega_{osc}$:For a sinusoidal phase detector, $\varepsilon_{ss} = \lim_{t \rightarrow \infty} \theta(t) = \sin^{-1}\left(\frac{\Delta\omega_{osc}}{NK_v}\right)$ For a nonsinusoidal (digital) phase detector, $\varepsilon_{ss} = \lim_{t \rightarrow \infty} \theta(t) = \frac{\Delta\omega_{osc}}{NK_v} \leq \beta$ The steady-state error is $\leq \beta$. A larger error indicates a failure to lock.

Maximum Sweep Rate of the Input Frequency:

Largest sweep rate of the input frequency for which the loop remains in lock.

$$\frac{d(\Delta\omega)}{dt} = \omega_n^2 \left(\frac{\text{radians/sec}}{\text{sec}} \right)$$

Maximum Sweep Rate for Aided Acquisition:

This is the case when the VCO is externally swept to speed up acquisition.

$$\frac{d(\Delta\omega)}{dt} = \frac{\omega_n^2}{2} \left(\frac{\text{radians/sec}}{\text{sec}} \right)$$

Type-2, Second-Order Loop

This type of PLL system generally uses the active PI filter as shown below.

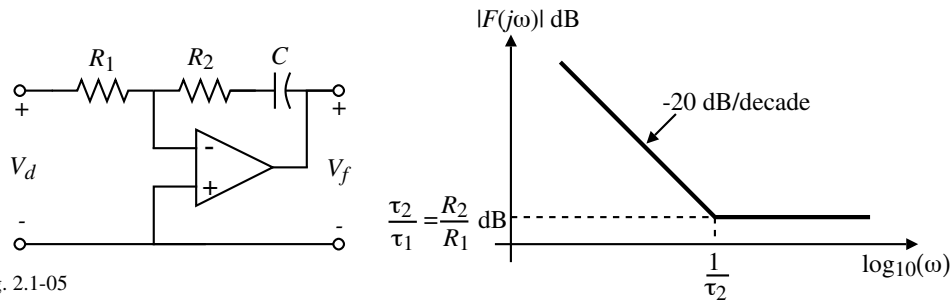

Filter Transfer Function:

$$F(s) = -\frac{1 + s\tau_2}{s\tau_1} = -\left(\frac{\tau_2}{\tau_1}\right)\left(\frac{s + 1/\tau_2}{s}\right) = -\left(\frac{R_2}{R_1}\right)\left(\frac{s + 1/\tau_2}{s}\right) \quad \text{where } \tau_1 = R_1C \text{ and } \tau_2 = R_2C$$

System Parameters:

$$\omega_n = \sqrt{\frac{K_v}{\tau_1}} \quad \text{and} \quad \zeta = \frac{1}{2}\sqrt{K_v\tau_2\frac{R_2}{R_1}} = \frac{1}{2}\tau_2\sqrt{\frac{K_v}{\tau_1}} = \frac{\tau_2\omega_n}{2}$$

3dB Bandwidth:

$$\omega_{-3dB} = \omega_n\sqrt{2\zeta^2 + 1 + \sqrt{(2\zeta^2 + 1)^2 + 1}}$$

Type-2, Second-Order Loop – Continued

Noise Bandwidth:

$$B_n = \frac{\omega_n}{2}\left(\zeta + \frac{1}{4\zeta}\right)$$

Hold Range:

Limited by the dynamic range of the loop components.

Lock (Capture) Range:

$$\Delta\omega_H = \beta N 2\zeta\omega_n$$

Lock (Capture) Time:

$$T_L = \frac{2\pi}{\omega_n}$$

Pull-in Range:

The pull-in range is the frequency range beyond the lock (capture) range over which the loop will lock after losing lock (skipping cycles).

- The pull-in range for a 2nd or higher order, type-2 loop is theoretically infinite and limited by the amplifier and phase detector offsets and by the dynamic range of the loop.
- A system with large offsets and a large frequency error may never lock.

Type-2, Second-Order Loop – Continued

Pull-in Time:

$$T_P = \tau_2 \left(\frac{\frac{\Delta\omega_{osc}}{N}}{\frac{R_2}{K_v R_1}} - \sin\theta_o \right)$$

where θ_o is the initial phase difference between the reference and VCO signals. Assume $\sin\theta_o = -1$ for the worst case.

Pull-out Range:

$$\Delta\omega_{PO} \approx 1.8N\beta\omega_n(1 + \zeta)$$

Frequency Acquisition Time:

$$T_a = T_P + T_L$$

If the frequency step is within the lock limit (one beat), then the pull-in time is zero.

Steady-state Phase Error:

The steady-state phase error of a type-2 system is zero for both a phase step and a frequency step.

Type-2, Second-Order Loop – Continued

Steady-state Phase Error – Continued:

The steady-state phase error due to a frequency ramp of $\Delta\omega_{osc}$ radians/sec./sec. is,

$$\text{For a sinusoidal phase detector, } \epsilon_{ss} = \lim_{t \rightarrow \infty} \theta(t) = \sin^{-1} \left[\left(\frac{R_1}{R_2} \right) \frac{\tau_2 \frac{d\Delta\omega_{osc}}{dt}}{NK_v} \right]$$

$$\text{For a nonsinusoidal (digital) phase detector, } \epsilon_{ss} = \lim_{t \rightarrow \infty} \theta(t) = \left[\left(\frac{R_1}{R_2} \right) \frac{\tau_2 \frac{d\Delta\omega_{osc}}{dt}}{NK_v} \right] \leq \beta$$

The steady-state error is $\leq \beta$. A larger error indicates a failure to lock.

Maximum Sweep Rate of Input Frequency:

Largest sweep rate of the input frequency for which the loop remains in lock.

$$\frac{d(\Delta\omega_{in})}{dt} = \beta\omega_n^2 \left(\frac{\text{radians/sec}}{\text{sec}} \right)$$

Maximum Sweep Rate for Aided Acquisition:

This is the case when the VCO is externally swept to speed up acquisition.

$$\frac{d(\Delta\omega_{osc})}{dt} = \frac{N\beta}{2\tau_2} \left(4B_n - \frac{1}{\tau_2} \right) \left(\frac{\text{radians/sec}}{\text{sec}} \right)$$

DESIGN OF A 450-475 MHz DPLL FREQUENCY SYNTHESIZER

Specifications

Design a DPLL frequency synthesizer that meets the following specifications:

Frequency Range:	450 – 475 MHz
Channel Spacing:	25 kHz
Modulation:	FM from 300 to 3000 Hz
Modulation Deviation:	± 5 kHz
Loop Type:	Type 2
Loop Order:	Second order
VCO Gain:	$K_o = 1.25 \text{ MHz/V} = 7.854 \text{ Mradians/sec./V}$
Phase Detector Type:	PFD ($\beta = 2\pi$)
Phase Detector Gain:	$K_d = 0.796 \text{ V/radian}$

(This example will be continued later in more detail concerning phase noise and spurs)

Note on channel spacing:

Carson's rule \rightarrow BW of an FM signal is $\approx 2[\Delta f_c + f_m(\text{max})] = 2(\pm 5 \text{ kHz} + 3 \text{ kHz}) = 16 \text{ kHz}$

If we assume a 9 kHz guard band, then

$$\text{Channel Spacing} = 9 \text{ kHz} + 16 \text{ kHz} = 25 \text{ kHz}$$

PLL System

Block Diagram:

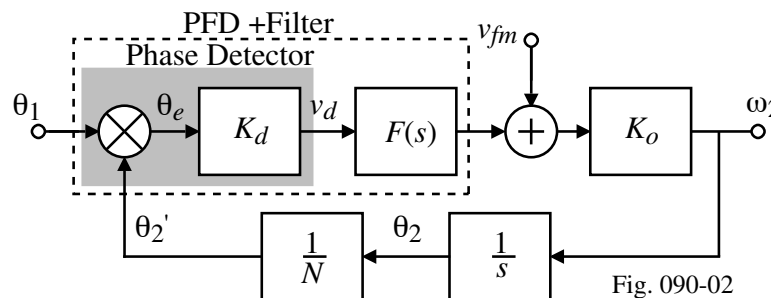

The pertinent transfer function for this problem is given as $\frac{\omega_2(s)}{V_f(s)}$ which is found as

$$\omega_2(s) = K_o \left[V_f(s) + F(s) K_d \left(\theta_1 - \frac{\omega_2(s)}{sN} \right) \right] = K_o \left[V_f(s) + F(s) K_d \theta_1 - \frac{F(s) K_d}{sN} \omega_2(s) \right]$$

Setting $\theta_1 = 0$ gives

$$\frac{\omega_2(s)}{V_f(s)} = \frac{K_o}{1 + \frac{F(s) K_d K_o}{sN}}$$

PLL System - Continued

The filter has a transfer function given as

$$F(s) = \frac{1 + \tau_2 s}{\tau_1 s}$$

The final form of the closed-loop transfer is given as

$$\frac{\omega_2(s)}{V_f(s)} = \frac{K_o}{1 + \frac{(1 + \tau_2 s)K_d K_o}{s^2 N \tau_1}} = \frac{s^2 K_o}{s^2 + \frac{K_d K_o \tau_2}{N \tau_1} s + \frac{K_d K_o}{N \tau_1}} = \frac{s^2 K_o}{s^2 + 2\zeta \omega_n s + \omega_n^2}$$

where,

$$\omega_n = \sqrt{\frac{K_d K_o}{N \tau_1}} \quad \text{and} \quad \zeta = \frac{\tau_2}{2} \sqrt{\frac{K_d K_o}{N \tau_1}}$$

Finding the Loop Parameters

1.) Division Ratio

$$N_{min} = \frac{450 \text{ MHz}}{25 \text{ kHz}} = 18,000 \quad \text{and} \quad N_{max} = \frac{475 \text{ MHz}}{25 \text{ kHz}} = 19,000$$

2.) Loop Bandwidth

To pass the 300Hz lower frequency limit, we require that the maximum -3dB frequency is 300Hz. Therefore, $B_L = 300\text{Hz}$.

3.) Damping Constant

For reasons discussed previously, we select $\zeta = 0.707$. Let us check to see if this is consistent with the design.

We know that,

$$\zeta = \frac{\tau_2}{2} \sqrt{\frac{K_d K_o}{N \tau_1}} \quad \rightarrow \quad \zeta = \frac{k}{\sqrt{N}}$$

$$\therefore \zeta_{max} = \frac{k}{\sqrt{N_{min}}} \quad \text{and} \quad \zeta_{min} = \frac{k}{\sqrt{N_{max}}} \quad \rightarrow \quad \zeta_{max} = \zeta_{min} \sqrt{\frac{N_{max}}{N_{min}}} = 1.0274 \zeta_{min}$$

Also, $\zeta = \sqrt{\zeta_{max} \cdot \zeta_{min}} = 0.707$, which gives

$$\zeta_{min}^2 (1.0274) = 0.5 \quad \rightarrow \quad \zeta_{min} = 0.6976 \quad \text{and} \quad \zeta_{max} = 1.0274 \cdot 0.6976 = 0.7167$$

Finding the Loop Parameters – Continued

4.) Natural frequency, ω_n

$$\omega_{-3dB} = \omega_n \sqrt{2\xi^2 + 1 + \sqrt{(2\xi^2 + 1)^2 + 1}} \rightarrow \omega_n = \frac{\omega_{-3dB}}{\sqrt{2\xi^2 + 1 + \sqrt{(2\xi^2 + 1)^2 + 1}}}$$

The maximum ω_n will occur at the minimum value of N and the minimum damping factor. Therefore,

$$\begin{aligned} \omega_n(\text{max}) &= \frac{\omega_{-3dB}}{\sqrt{2\xi_{\min}^2 + 1 + \sqrt{(2\xi_{\min}^2 + 1)^2 + 1}}} \\ &= \frac{2\pi \cdot 300}{\sqrt{2(0.6976)^2 + 1 + \sqrt{(2(0.6976)^2 + 1)^2 + 1}}} = 980 \text{ radians/sec.} \end{aligned}$$

$$\omega_n(\text{min}) = \frac{\omega_{-3dB}}{\sqrt{2\xi_{\max}^2 + 1 + \sqrt{(2\xi_{\max}^2 + 1)^2 + 1}}} = 910 \text{ radians/sec.}$$

$$\therefore \omega_n = \sqrt{\omega_n(\text{max}) \cdot \omega_n(\text{min})} = 944$$

Loop Parameter Summary:

Frequency (MHz)	N	ω_n (rads./sec.)	ζ	Bandwidth (Hz)
450.00	18,000	910	0.7167	300
475.00	19,000	980	0.6976	300

Design of the Loop Filter

The loop filter selected is the active PI using the single-ended realization below.

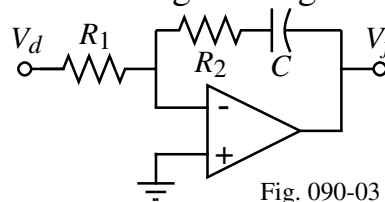

Fig. 090-03

The transfer function is,

$$F(s) = \frac{V_f(s)}{V_d(s)} = \frac{sR_2C + 1}{sR_1C} = \frac{s\tau_2 + 1}{s\tau_1} \rightarrow \tau_1 = R_1C \quad \text{and} \quad \tau_2 = R_2C$$

1.) Time constants

We will use the date for $N = 18,000$ to design the filter.

$$\tau_1 = \frac{K_d K_o}{N \omega_n^2} = \frac{0.796 \cdot 7.854 \times 10^6}{18,000 (910)^2} = 0.419 \text{ ms}$$

$$\tau_2 = \frac{2\xi}{\omega_n} = \frac{2 \cdot 0.7167}{910} = 1.575 \text{ ms}$$

2.) Loop filter design

Select $R_1 = 2.4 \text{ k}\Omega$ which gives

$$C = \frac{\tau_1}{R_1} = \frac{0.419 \times 10^{-3}}{2.4 \times 10^3} = 0.175 \text{ }\mu\text{F} \quad \text{and} \quad R_2 = \frac{\tau_2}{C} = \frac{1.575 \times 10^{-3}}{0.175 \times 10^{-6}} = 9.0 \text{ k}\Omega$$

Design of the Loop Filter – Continued

3.) Simulated response of the filter.

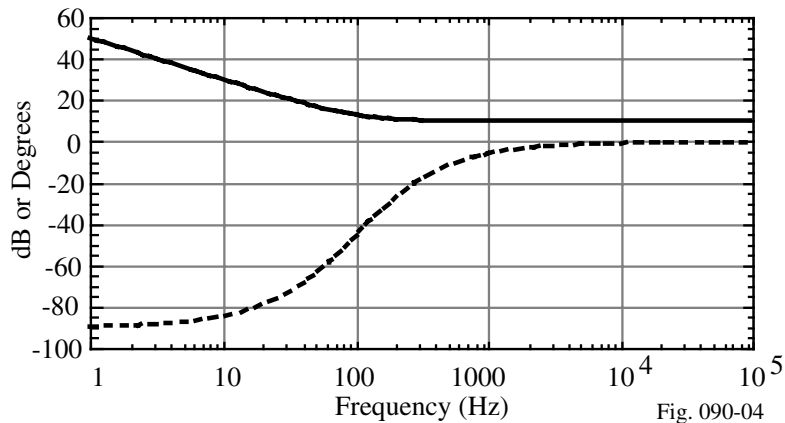

4.) Differential version of the filter.

It is necessary to use a differential input in order to interface with the PFD.

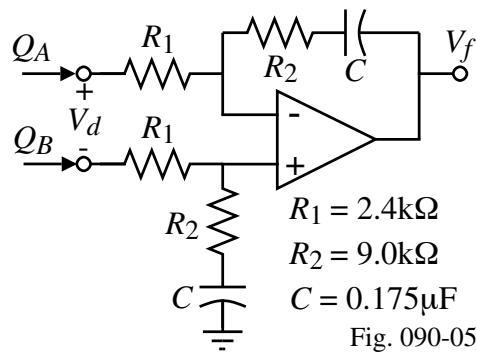

Loop Stability

1.) Loop Gain.

The loop gain for $N = 18,000$ is given by

$$\begin{aligned}
 LG(s) &= \frac{K_d K_o F(s)}{Ns} = \frac{K_v (s\tau_2 + 1)}{s^2 N \tau_1} = \frac{7.854 \times 10^6 \cdot 0.796 (1 + 1.575 \times 10^{-3} s)}{0.419 \times 10^{-3} \cdot 18,000 s^2} \\
 &= \frac{828.83 \times 10^3 (1 + 1.575 \times 10^{-3} s)}{s^2}
 \end{aligned}$$

2.) Bode Plot

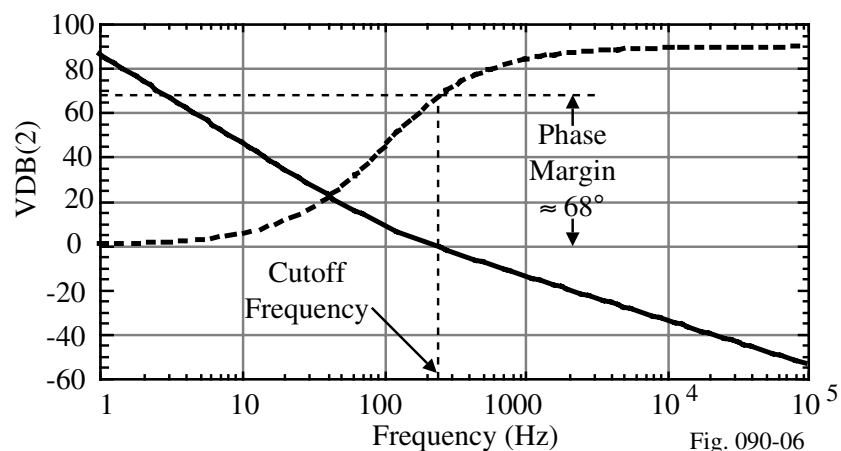

(We will continue this example later.)

MEASUREMENT OF PLL PERFORMANCE

(The device under test in this section is the Exar XR-S200.)

Measurement of Center Frequency, f_o

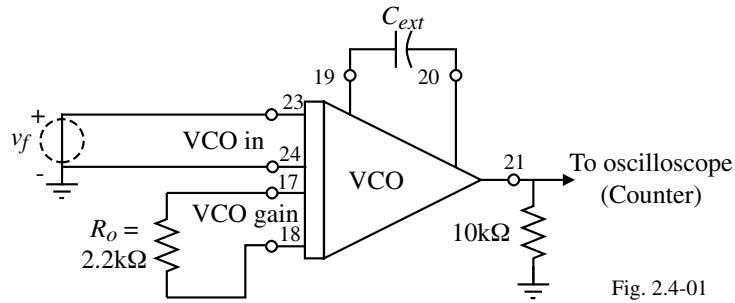
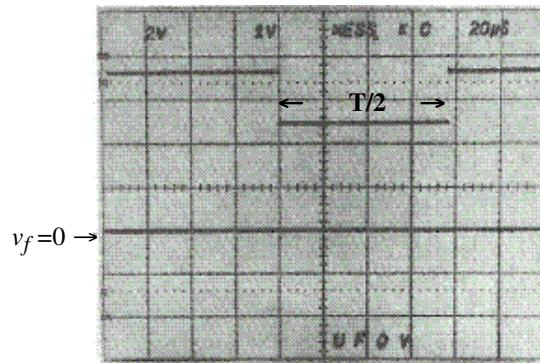

Fig. 2.4-01

Results:



$$T/2 \approx 76\mu\text{s}$$

$$\text{or } T = 152\mu\text{s}$$

$$\therefore f_o = 1/T = \underline{6.54 \text{ kHz}}$$

Measurement of the VCO Gain, K_o

Use the same measurement configuration as for f_o . Vary v_f and measure the output frequency of the VCO.

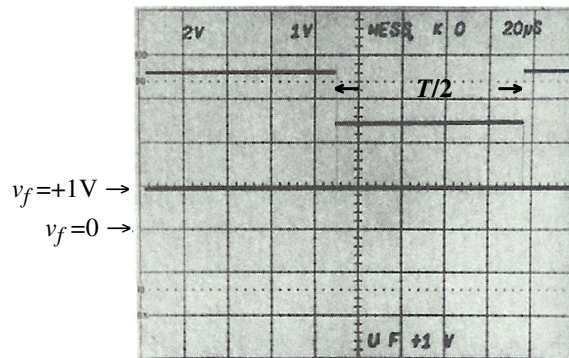

$$T/2 \approx 85\mu\text{s}$$

$$\text{or } T = 170\mu\text{s}$$

$$\therefore f_o = 1/T = 5.88 \text{ kHz}$$

Calculation of K_o .

$$K_o = \frac{\Delta\omega}{\Delta v_f} = \frac{2\pi(6.54-5.88)}{1-0} \times 10^3 = 4.13 \times 10^3 \frac{1}{\text{V}\cdot\text{sec}}$$

Measurement of the Phase Detector Gain, K_d

Test circuit:

Measurement Principle:

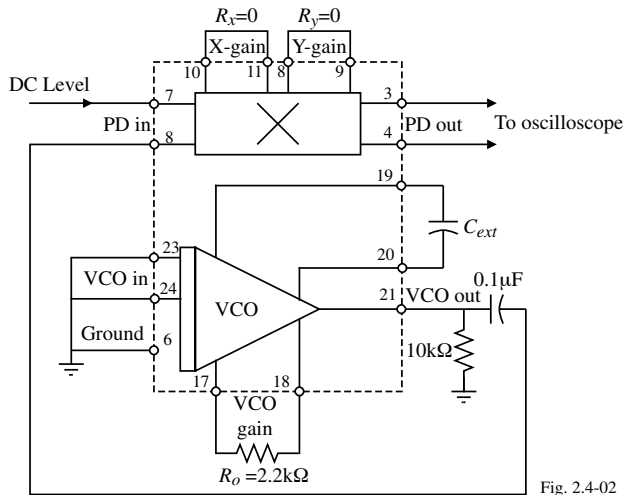

Fig. 2.4-02

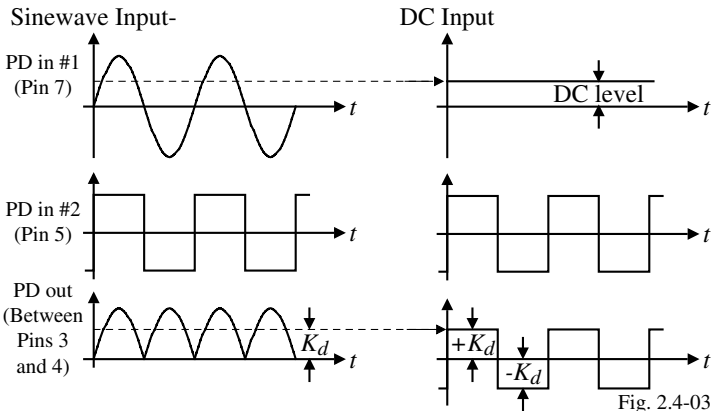

Fig. 2.4-03

The above measurement assumes that $\theta_e = 90^\circ$ so that $\overline{v_d} = K_d \sin 90^\circ = K_d$

For a sinewave input, the dc output of the PD is $2/\pi$ of the peak sinusoidal voltage.

If a dc voltage is applied at the PD input of $(\sqrt{2}/1) \times (2/\pi) V_{peak} \approx 0.9 V_{peak}$, then K_d is simply 1/2 of the peak-to-peak output of the phase detector.

Measurement of K_d – Continued

$v_1 = 10, 20, 30$ and 40 mV (rms)

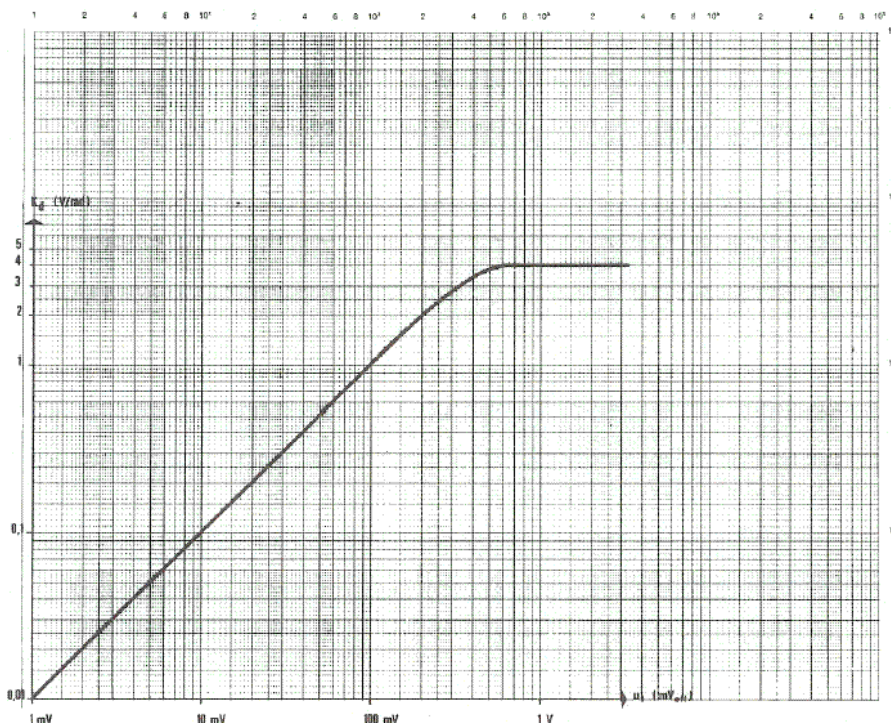

More values indicate that the PD saturates at 0.4V (rms)

Measurement of ω_n , ζ , and the Lock Range $\Delta\omega_L$

Test circuit:

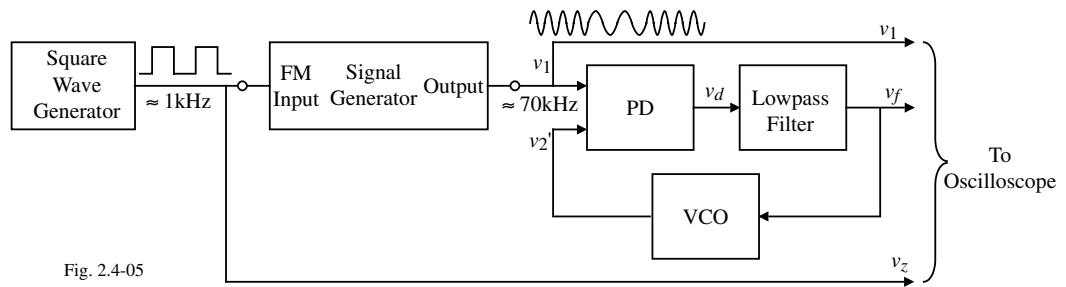

Waveforms:

Fig. 2.4-05

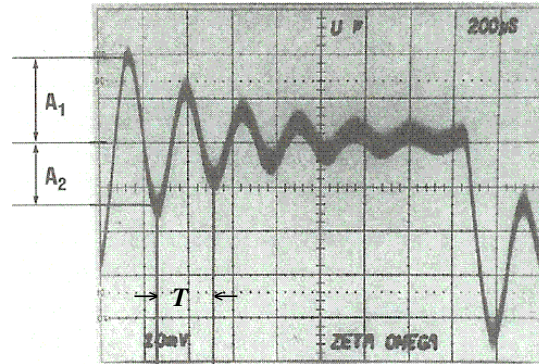
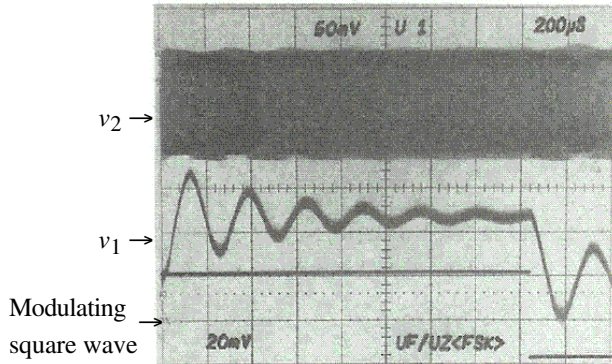

Parameter extraction:

With $A_1=1.9$, $A_2=1.4$, $\zeta = \frac{\ln(A_1/A_2)}{\sqrt{\pi^2 + [\ln(A_1/A_2)]^2}}$ and $\omega_n = \frac{2\pi}{T\sqrt{1-\zeta^2}} \Rightarrow \zeta = 0.8$ and $f_n = 4.1\text{kHz}$

Measurement of ω_n , ζ , and the Lock Range $\Delta\omega_L$ – Continued

Measurement of $\Delta\omega_L$:

1.) The signal generator is adjusted to generate two frequencies, ω_{high} and ω_{low} such that,

$$\omega_{high} > \omega_o + \Delta\omega_p$$

2.) Set $\omega_{low} = \omega_{high}$ (the amplitude of the square wave generator will be zero)

3.) Decrease ω_{low} .

4.) When $\omega_{low} \approx \omega_o + \Delta\omega_L$, the PLL will lock.

$$\therefore \Delta\omega_L \approx \omega_{low} - \omega_o$$

Measurement of the Phase Transfer Function, $H(j\omega)$

Since most signal generators are not phase modulated, use a frequency modulated signal generator instead as follows.

Test circuit:

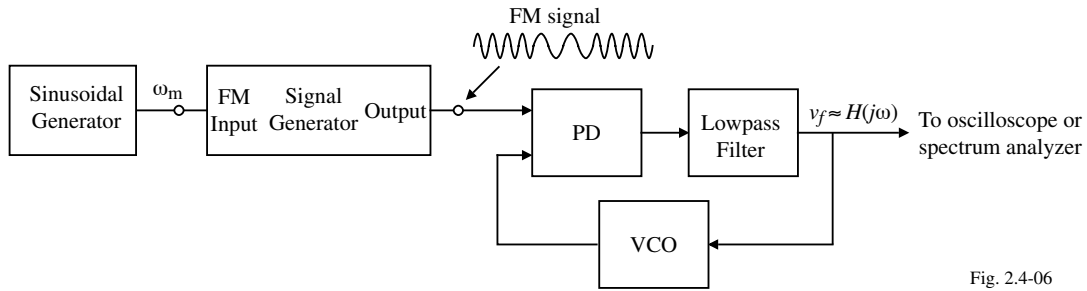

Fig. 2.4-06

Principle:

$$\omega_1 = \omega_o + \Delta\omega \sin\omega_m t \quad \rightarrow \quad \theta_1(t) = \int_0^t \omega_1 dt = -\frac{\Delta\omega}{\omega_m} \cos\omega_m t \quad \rightarrow \quad |\theta_1(j\omega)| = \frac{\Delta\omega}{\omega_m}$$

$$H(j\omega) = \frac{\theta_2(j\omega)}{\theta_1(j\omega)} \quad \text{and} \quad \theta_2(j\omega) = \frac{K_o}{j\omega_m} V_f(j\omega_m)$$

$$\therefore |H(j\omega)| = \frac{K_o V_f(j\omega_m)}{\Delta\omega}$$

What about $\Delta\omega$?

As long as $\Delta\omega$ is small enough, the PD operates in its linear region and $v_f(t)$ is an undistorted sinewave (see next slide).

Measurement of $H(j\omega)$ – Continued

$\Delta\omega$ small enough for linear operation.

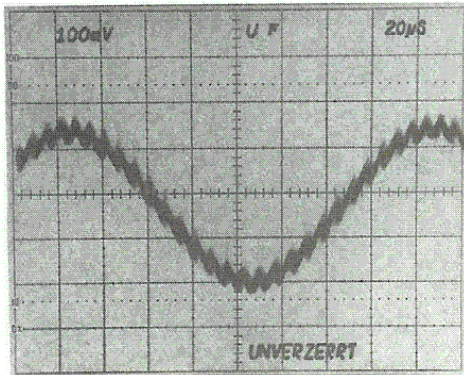

$\Delta\omega$ too large for linear operation.

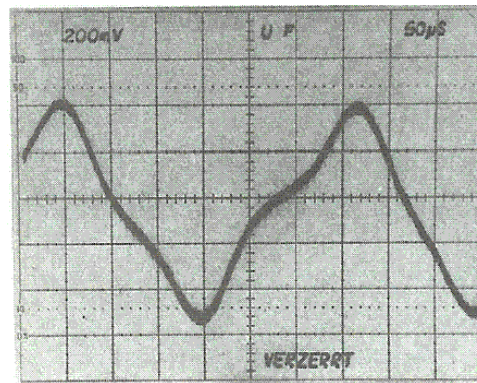

Implementation:

- 1.) Can plot the frequency response point-by-point.
- 2.) Use a spectrum analyzer
 - Sweep generator rate \ll Spectrum analyzer sweep rate
 - Watch out that resonance peaks in the response don't cause nonlinear operation.

Typical results: \rightarrow

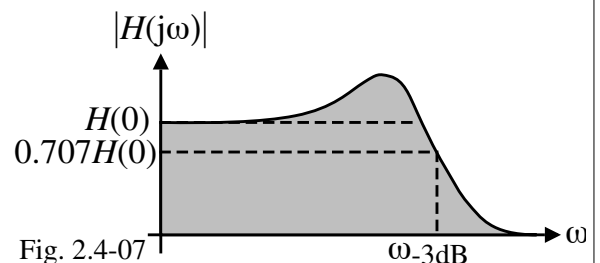
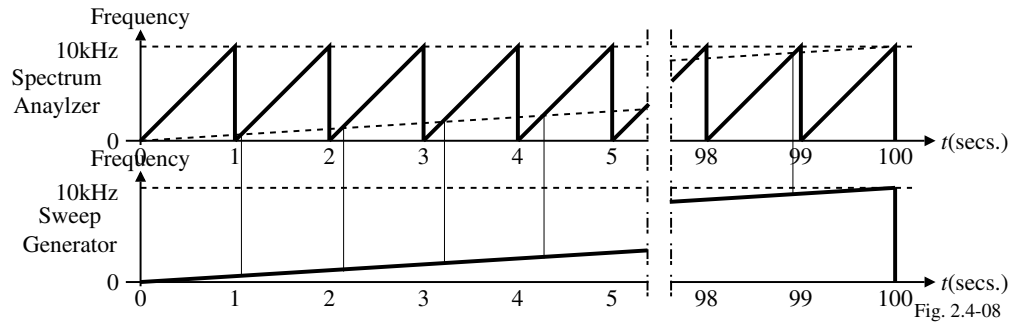

Fig. 2.4-07

Measurement of $H(j\omega)$ – Continued

Timing relationship between the sweep generator and the spectrum analyzer:



Basically, f_m should approximate a constant during one sweep period of the analyzer.

Problem due to resonance peaks that cause nonlinear operation:

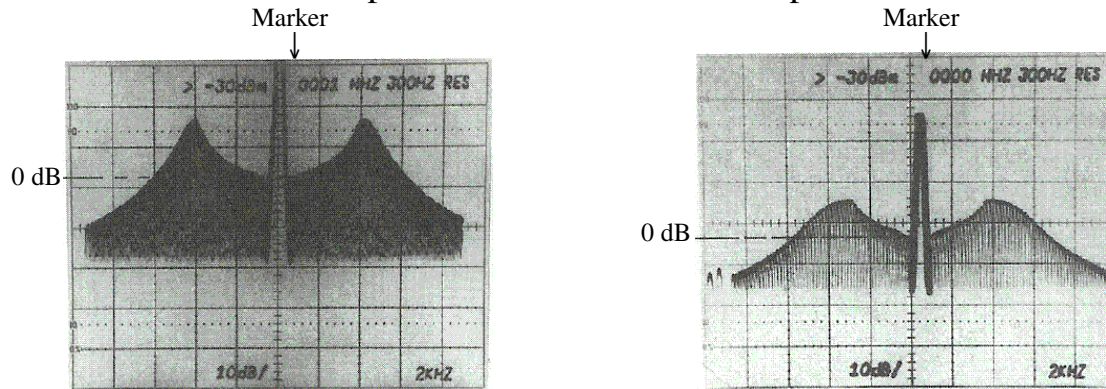

CMOS Phase Locked Loops

© P.E. Allen - 2003

SUMMARY

- PLL Design Equations
 - Basic design equations for
 - Type-I, first-order loop
 - Type-I, second-order loop
 - Type-II, second-order loop
- Design of a 450-475 MHz DPLL Frequency Synthesizer
 - PFD plus Charge Pump
 - Design of active PI filter
 - Stability
- Measurements of PLL Performance
 - How to experimentally measure the various performance parameters of a PLL