

# LECTURE 040 –DIGITAL PHASE LOCK LOOPS (DPLLs)

## INTRODUCTION

### Introduction

Objective:

Understand the operating principles and classification of DPLLs.

Organization:

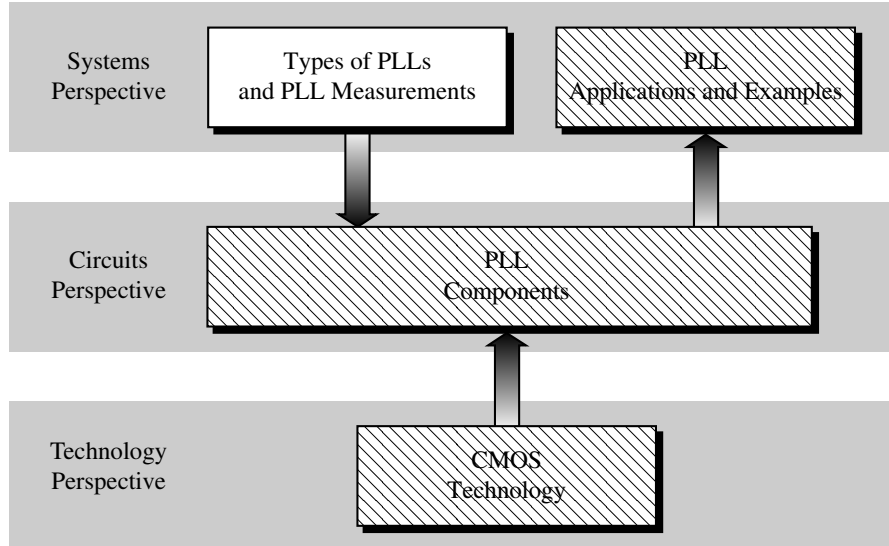

Fig. 030901-01

### Outline

- Building Blocks of the DPLL
- Dynamic Performance of the DPLL
- Noise Performance of the DPLL
- DPLL Design Procedure
- DPLL System Simulation

## BUILDING BLOCKS OF THE DPLL

### Block Diagram of the DPLL

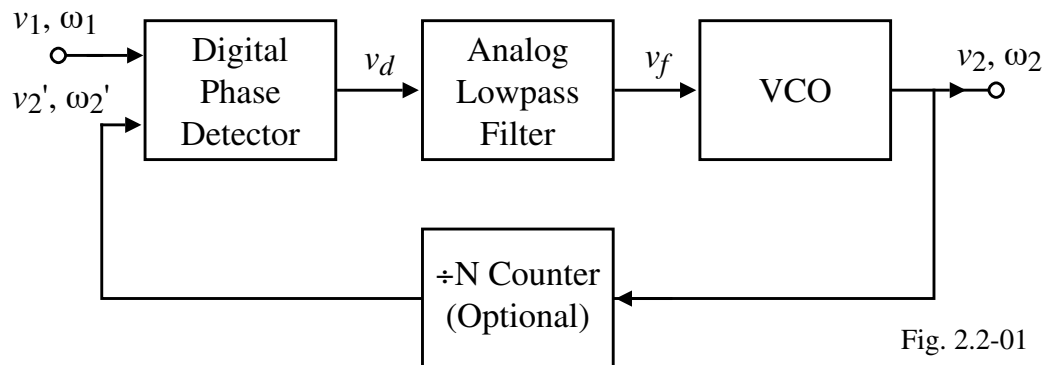

Fig. 2.2-01

- The only digital block is the phase detector and the remaining blocks are similar to the LPLL
- The divide by N counter is used in frequency synthesizer applications.

$$\omega_2' = \omega_1 = \frac{\omega_2}{N} \quad \rightarrow \quad \omega_2 = N \omega_1$$

## DIGITAL PHASE DETECTORS

### Introduction

Key assumption in digital phase detectors:  $v_1(t)$  and  $v_2(t)$  are square waves. This may require amplification and limiting.

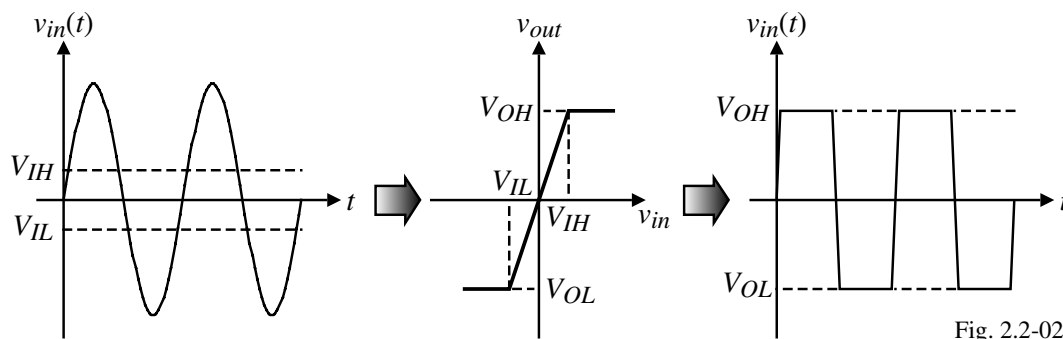
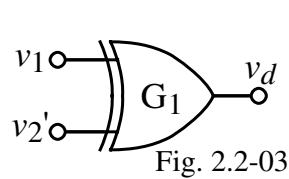

Fig. 2.2-02

Types of digital phase detectors:

- 1.) EXOR gate
- 2.) The edge-triggered JK flip-flop
- 3.) The phase-frequency detector

### The EXOR Gate



$v_1$	$v_2'$	$v_d$
0	0	0
0	1	1
1	0	1
1	1	0

Zero Phase Error:

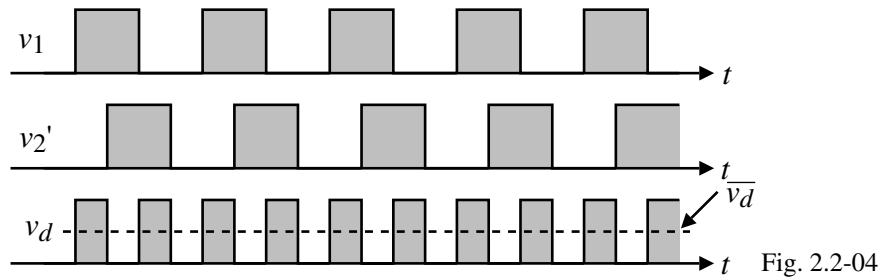

Positive Phase Error:

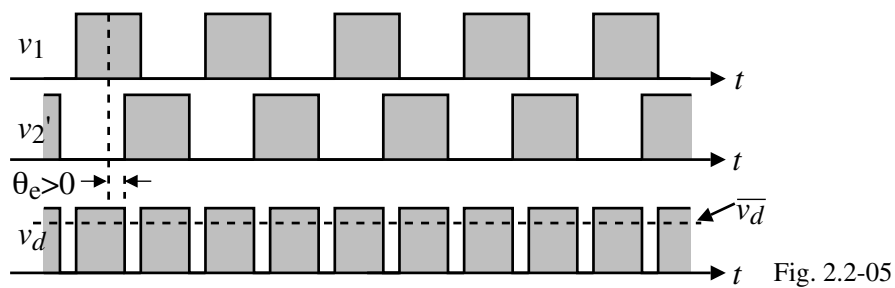

### EXOR Gate – Continued

Assume that the average value of  $v_d$ , is shifted to zero for zero phase error,  $\theta_e$ .  $\overline{v_d}$  can be plotted as,

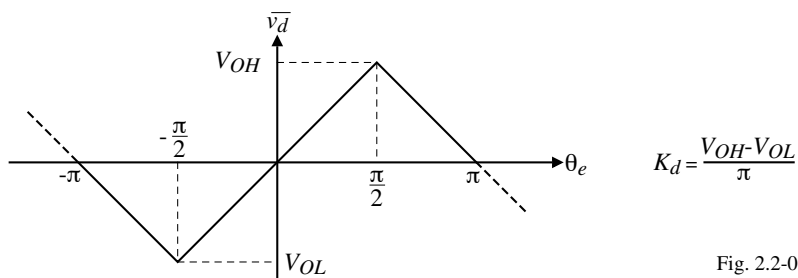

If  $v_1$  and  $v_2'$  are asymmetrical (have different duty cycles), then  $\overline{v_d}$  becomes,

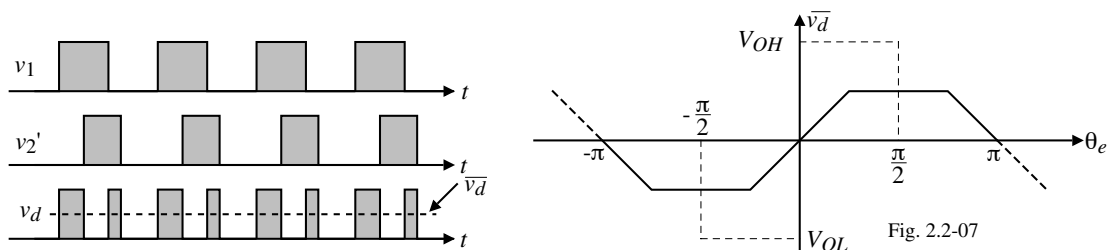

The effect of waveform asymmetry is to reduce the loop gain of the DPLL and also results in a smaller lock range, pull-in range, etc.

### JK Flip-Flop

The JK Flip-Flop is not sensitive to waveform asymmetry because it is edge-triggered.

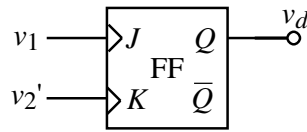
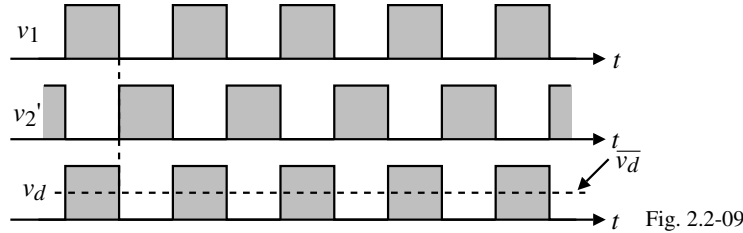

Fig. 2.2-08

$v_1$	$v_2'$	$Q_{n+1}$
0	0	$Q_n$
0	1	0
1	0	1
1	1	$\overline{Q_n}$

Zero Phase Error (Assume rising edge triggered):



Positive Phase Error:

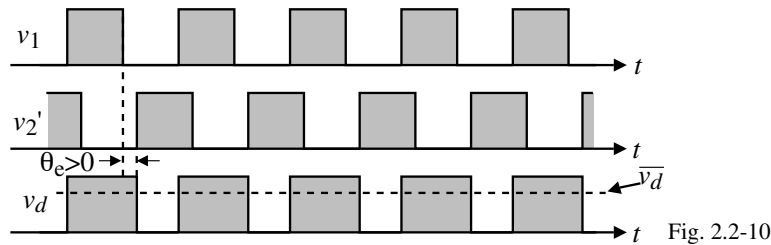

### JK Flip-Flop Phase Detector – Continued

Input-Output Characteristic:

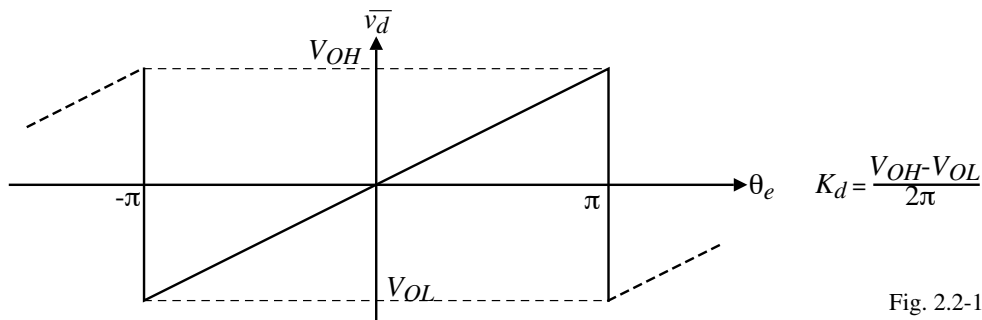

Fig. 2.2-11

Comments:

- Symmetry of  $v_1$  and  $v_2'$  is unimportant
- Both the EXOR and the JK flip-flop have a severely limited pull-in range if the loop filter does not have a pole at zero.

### The Phase-Frequency Detector (PFD)

The PFD can detect both the phase and frequency difference between  $v_1$  and  $v_2'$ .

Conceptual diagram:

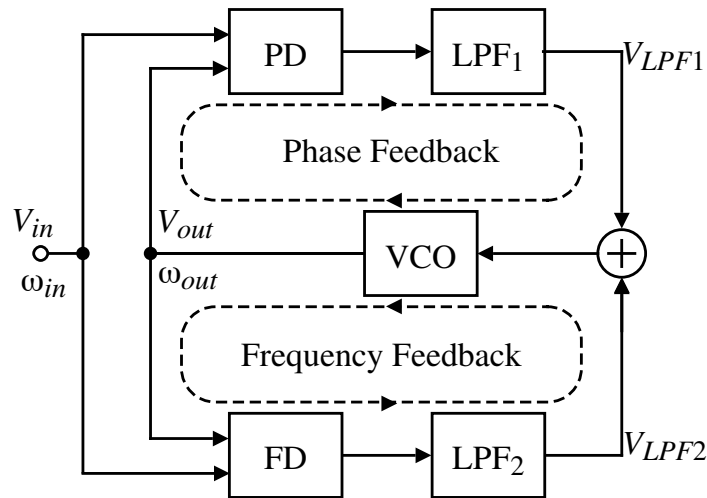

The output signal of the PFD depends on the phase error in the locked state and on the frequency error in the unlocked state.

Consequently, the PFD will lock under any condition, irrespective of the type of loop filter used.

### The PFD – Continued

PFD implementation:

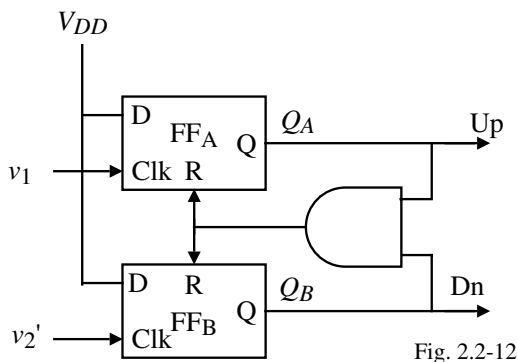

Fig. 2.2-12

No AND Gate		With AND Gate	
$Q_A$	$Q_B$	$Q_A$	$Q_B$
0	0	1	0 → State = +1
1	0	0	0 → State = 0
0	1	0	1 → State = -1
1	1		

PFD State Diagram:

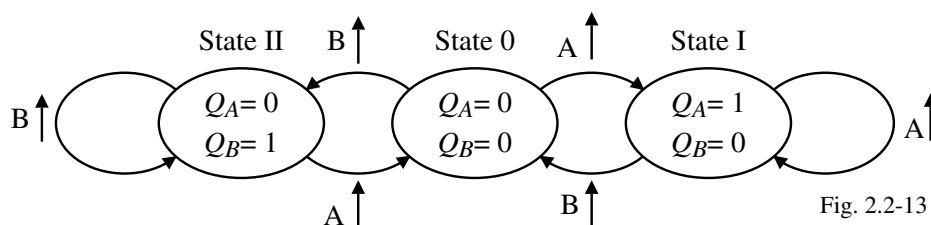
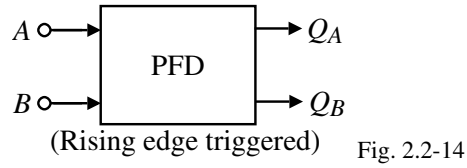

Fig. 2.2-13

Unlike the EXOR gates and the R-S latches, the PFD generates two outputs which are not complementary.

### Illustration of a PFD

PFD ( $\omega_A = \omega_B$ ):



$\phi_A > \phi_B$ :

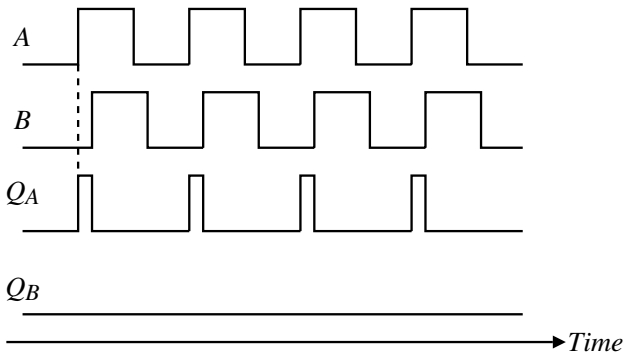

$\phi_A < \phi_B$ :

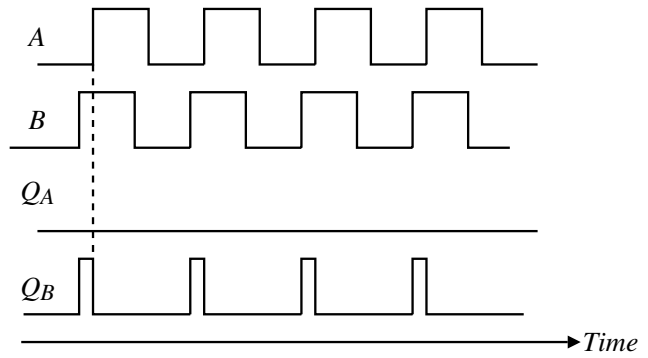
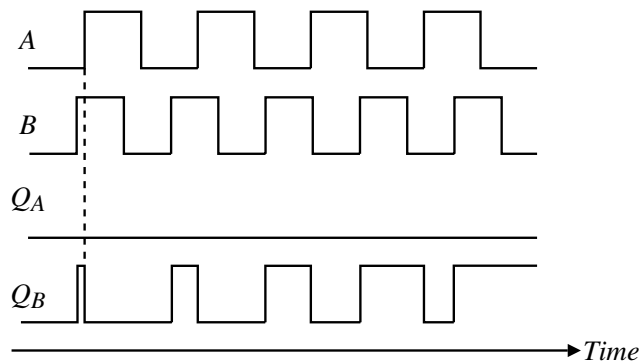

Fig. 2.2-15

### Illustration of the PFD- Continued

$\omega_A < \omega_B$ :



$\omega_A > \omega_B$ :

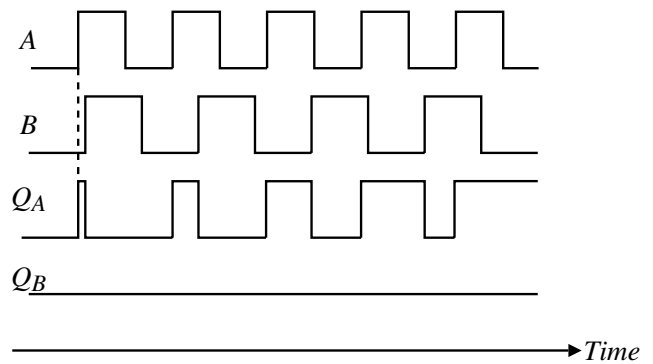

Fig. 2.2-16

### PFD – Continued

Plot of the PFD output versus phase error:

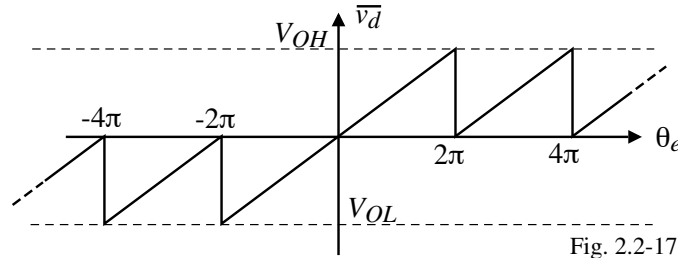

Fig. 2.2-17

When  $\theta_e$  exceeds  $\pm 2\pi$ , the PFD behaves as if the phase error recycled at zero.

$$\therefore K_d = \frac{V_{OH} - V_{OL}}{4\pi}$$

A plot of the averaged duty cycle of  $v_d$  versus  $\omega_1/\omega_2'$  ( $\omega_A/\omega_B$ ) in the unlocked state of the DPLL:

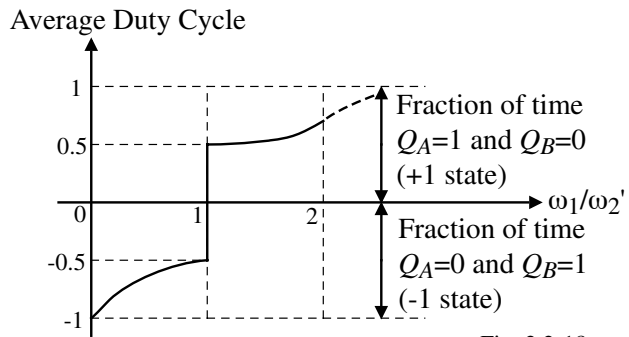

Fig. 2.2-18

## CHARGE PUMPS

### What is a Charge Pump?

A charge pump consists of two switched current sources controlled by  $Q_A$  and  $Q_B$  which drive a capacitor or a combination of a resistor and a capacitor to form a filter for the PLL with a pole at the origin.

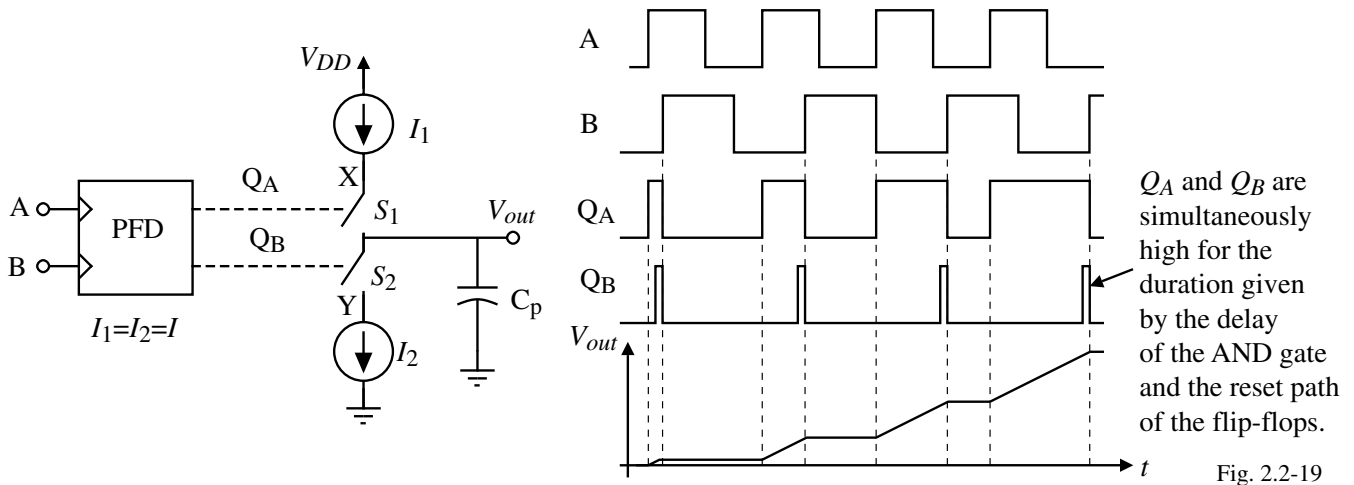

Fig. 2.2-19

$\omega_A > \omega_B$  or  $\omega_A = \omega_B$  but  $\theta_A > \theta_B$ :  $S_1$  is on and  $V_{out}$  increases.

$\omega_A < \omega_B$  or  $\omega_A = \omega_B$  but  $\theta_A < \theta_B$ :  $S_2$  is on and  $V_{out}$  decreases.

## A Charge-Pump PLL

Block diagram:

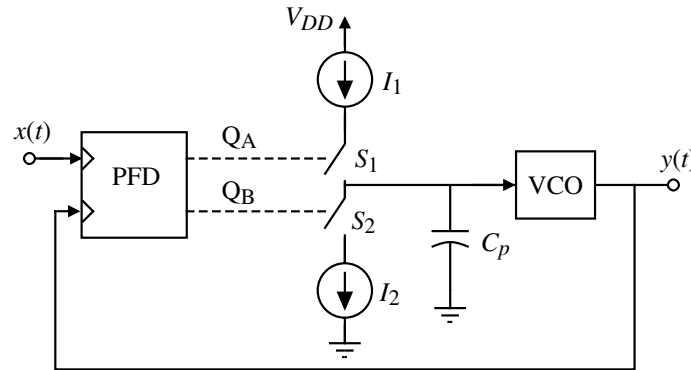

Fig. 2.2-20

The charge pump and capacitor  $C_p$  serve as the loop filter for the PLL.

The charge pump can provide infinite gain for a static phase shift.

## Step Response of a Charge Pump PLL

Assume that the period of the input is  $T_1$  and the charge pump provides a current of  $\pm I_p$  to the capacitor  $C_p$ .

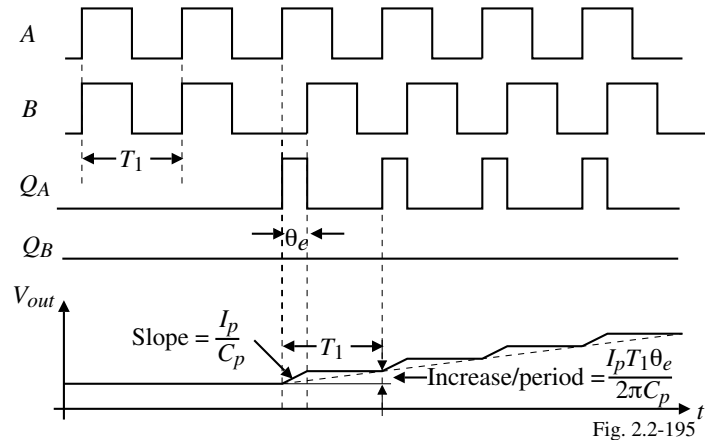

Fig. 2.2-195

Detector gain?

Since the steady-state gain =  $\infty$ , it is more meaningful to define  $K_d$  as follows,

$$\text{Amount of } v_d(t) \text{ increase per period } (T_1) = \frac{I_p}{C_p} \times \frac{\theta_e}{2\pi/T_1} = \frac{I_p T_1 \theta_e}{2\pi C_p}$$

$$\text{Average slope per period} = \frac{I_p T_1 \theta_e}{2\pi C_p} \times \frac{1}{T_1} = \frac{I_p \theta_e}{2\pi C_p}$$

$$v_d(t) = \text{Average Slope} \cdot \Delta\theta = \frac{I_p}{2\pi C_p} \cdot \theta_e \mu(t)$$

Taking the Laplace transform gives,

$$V_d(s) = \frac{I_p}{2\pi C_p s} \frac{\theta_e}{s} \quad \rightarrow \quad K_d = \frac{I_p}{2\pi C_p} \frac{\text{V}}{\text{rads}}$$

## A Charge-Pump PLL – Continued

$$\frac{Y(s)}{X(s)} = \frac{V_2(s)}{V_1(s)} = ?$$

$$Y(s) = \frac{K_o}{s} V_d(s) = \frac{K_o K_d}{s^2} [X(s) - Y(s)] \quad \rightarrow \quad \frac{Y(s)}{X(s)} = \frac{K_o K_d}{s^2 + K_o K_d}$$

which has poles at  $\pm j\sqrt{K_o K_d}$ . To avoid instability, a zero must be introduced by the resistor in series with  $C_p$ .

$$V_d(s) = \frac{I}{2\pi} \left( R + \frac{1}{sC_p} \right) = \frac{I}{s2\pi C_p} (sRC_p + 1) = \frac{K_d}{s} (s\tau_p + 1)$$

$$\therefore Y(s) = \frac{K_o}{s} V_d(s) = \frac{K_o K_d}{s^2} (s\tau_p + 1) [X(s) - Y(s)]$$

$$Y(s) \left[ 1 + \frac{K_o K_d}{s^2} (s\tau_p + 1) \right] = \frac{K_o K_d}{s^2} (s\tau_p + 1) X(s)$$

$$\frac{Y(s)}{X(s)} = \frac{K_o K_d (s\tau_p + 1)}{s^2 + K_o K_d \tau_p s + K_o K_d}$$

Equating to the standard second-order denominator gives,

$$\omega_n = \sqrt{K_o K_d} \quad \text{and} \quad \zeta = \frac{\omega_n \tau_p}{2}$$

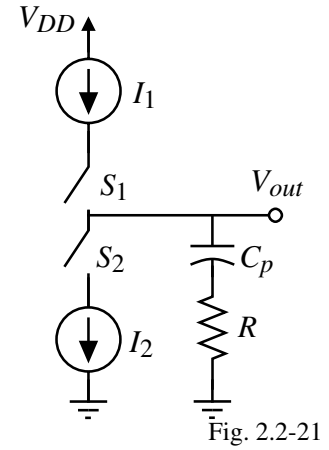

## Nonideal Effects of Charge-Pumps

### 1.) Dead zone.

A dead zone occurs when  $Q_A$  or  $Q_B$  do not reach their full logic levels. This is due to delay differences in the AND gate and the flip-flops. It is easily removed by proper synchronization of the delays.

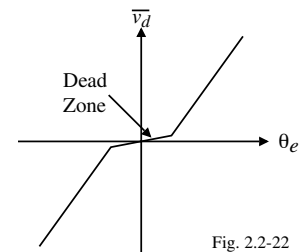

Fig. 2.2-22

### 2.) Mismatch between $I_1$ and $I_2$ .

To eliminate the dead zone,  $Q_A$  and  $Q_B$  can be simultaneously high for a small time. If  $I_1 \neq I_2$ , the output varies even though  $\theta_e = 0$ . (Can introduce spurs.)

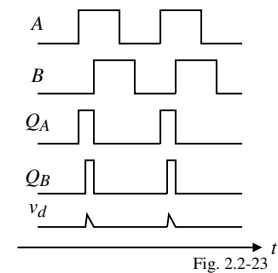

Fig. 2.2-23

### 3.) Charge injection.

When the  $S_1$  and  $S_2$  switches turn off, they can inject/remove charge from  $C_p$ . Changes  $\omega_2$ .

### 4.) Charge sharing.

If  $X \rightarrow V_{DD}$  and  $Y = 0$  when  $S_1$  and  $S_2$  are off, the VCO will experience a jump when  $S_1$  or  $S_2$  turns on. This periodic effect introduces sidebands (spurs) at the output.

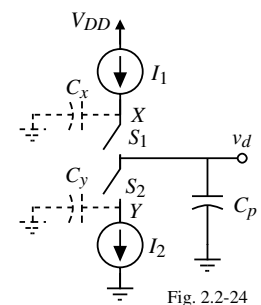

Fig. 2.2-24

## DYNAMIC PERFORMANCE OF THE DPLL

### Types of PLLs

Type I – Open-loop transfer function has one pole at the origin.

Type II – Open-loop transfer function has two poles at the origin.

The above transfer functions may also have other roots but not at the origin.

### Model for the DPLL

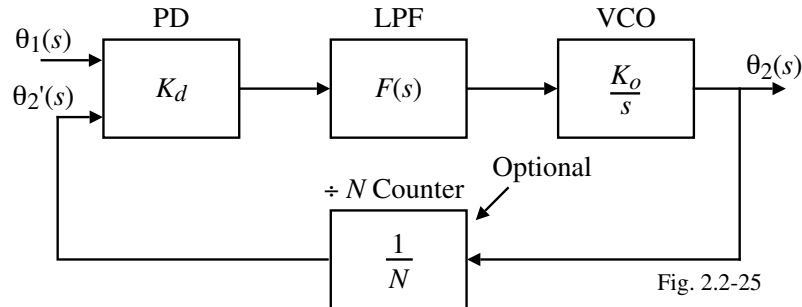

Various configurations of the DPLL:

1.) Phase detector – EXOR, J-K flip-flop, or PFD

2.) Filter –

Passive lag with or without a charge pump

Active lag with or without a charge pump

Active PI with or without a charge pump

### Loop Filters

1.) Passive lag-

$$\text{PD} \quad \rightarrow \quad F(s) = \frac{1 + s\tau_2}{1 + s(\tau_1 + \tau_2)}$$

$$\text{PFD} \quad \rightarrow \quad F(s) \approx \frac{1 + s\tau_2}{s(\tau_1 + \tau_2)}$$

Experimental results using the PFD with a passive lag filter show that the gain of the passive filter is not constant. As a result, the filter dynamics become nonlinear.

2.) Active lag-

$$\text{PD} \quad \rightarrow \quad F(s) = K_a \frac{1 + s\tau_2}{1 + s\tau_1}$$

$$\text{PFD} \quad \rightarrow \quad F(s) \approx \frac{1 + s\tau_2}{s\tau_1}$$

3.) Active PI-

$$\text{PD or PFD} \quad \rightarrow \quad F(s) = \frac{1 + s\tau_2}{s\tau_1}$$

### The Hold Range, $\Delta\omega_H$

The hold range,  $\Delta\omega_H$ , is the frequency range within which the PLL operation is statically stable. The hold range for various types of DPLLs are:

Type of PD	EXOR	EXOR	EXOR	JK-FF	JK-FF	JK-FF	PFD
Loop Filter	Passive Lag	Active Lag	Active PI	Passive Lag	Active Lag	Active PI	All Filters
$\Delta\omega_H$	$\frac{K_o K_d (\pi/2)}{N}$	$\frac{K_o K_d (\pi/2)}{N}$	$\infty$	$\frac{K_o K_d \pi}{N}$	$\frac{K_o K_d K_a \pi}{N}$	$\infty$	$\infty$

### The Lock Range, $\Delta\omega_L$

The lock range is the offset between  $\omega_1$  and  $\omega_2/N$  that causes the DPLL to acquire lock with one beat note between  $\omega_1$  and  $\omega_2' = \omega_2/N$ .

1.) PD = EXOR

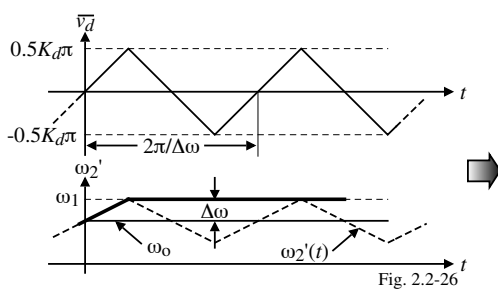

Recall that  $\Delta\omega_L(\text{LPLL}) = 2\zeta\omega_n$   
 and  $\Delta\omega_L \propto \text{Range of } \theta_e = \Delta\theta_e$   
 But,  $\Delta\theta_e(\text{EXOR}) = 0.5\pi \Delta\theta_e(\text{LPLL})$   
 $\therefore \Delta\omega_L = 0.5\pi(2\zeta\omega_n) = \pi\zeta\omega_n$

$$\Delta\omega_L = \pi\zeta\omega_n$$

2.) PD = JK-Flip flop

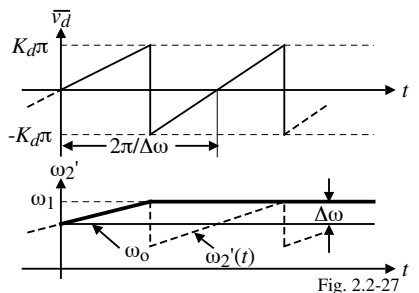

$\Delta\theta_e(\text{EXOR}) = \pi \Delta\theta_e(\text{LPLL})$   
 $\therefore \Delta\omega_L = \pi(2\zeta\omega_n)$

$$\Delta\omega_L = 2\pi\zeta\omega_n$$

3.) PD = PFD

$$\Delta\theta_e(\text{PFD}) = 2\pi \Delta\theta_e(\text{LPLL}) \rightarrow \Delta\omega_L = 2\pi(2\zeta\omega_n) \rightarrow \Delta\omega_L = 4\pi\zeta\omega_n$$

The lock time for all cases is  $T_p \approx 2\pi/\omega_n$ .

### The Pull-In Range, $\Delta\omega_p$ , and the Pull-In Time, $T_p$

The pull-in range,  $\Delta\omega_p$ , is the largest  $\Delta\omega = |\omega_1 - \omega_2|$  for which an unlocked loop will lock. The pull-in time,  $T_p$ , is the time required for the loop to lock.

EXOR as the PD:

Waveforms-

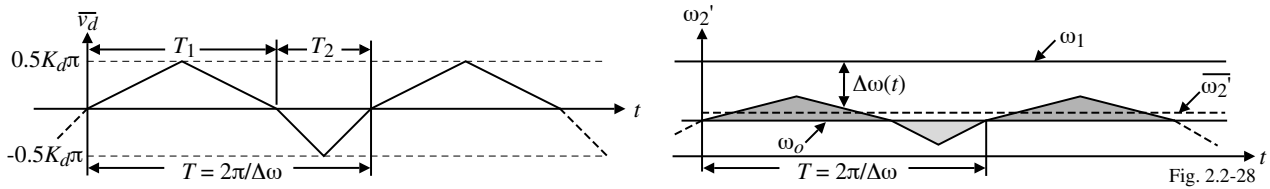

$T_1 > T_2$  because  $\Delta\omega$  is smaller when  $\overline{v_d}$  is positive and larger when  $\overline{v_d}$  is negative.

Results-

Type of Filter	$\Delta\omega_p$ (Low loop gains)	$\Delta\omega_p$ (High loop gains)	Pull-in Time, $T_p$
Passive Lag	$\frac{\pi}{2} \sqrt{2\xi\omega_n K_o K_d - \omega_n^2}$	$\frac{\pi}{\sqrt{2}} \sqrt{\xi\omega_n K_o K_d}$	$\frac{4}{\pi^2} \frac{\Delta\omega_o^2}{\xi\omega_n^3}$
Active Lag	$\frac{\pi}{2} \sqrt{2\xi\omega_n K_o K_d - \frac{\omega_n^2}{K_a}}$	$\frac{\pi}{\sqrt{2}} \sqrt{\xi\omega_n K_o K_d}$	$\frac{4}{\pi^2} \frac{\Delta\omega_o^2}{\xi\omega_n^3}$
Active PI	$\infty$	$\infty$	$\frac{4}{\pi^2} \frac{\Delta\omega_o^2}{\xi\omega_n^3}$

### The Pull-In Range, $\Delta\omega_p$ , and the Pull-In Time, $T_p$ -Continued

JK Flip-Flop as the PD:

Waveforms-

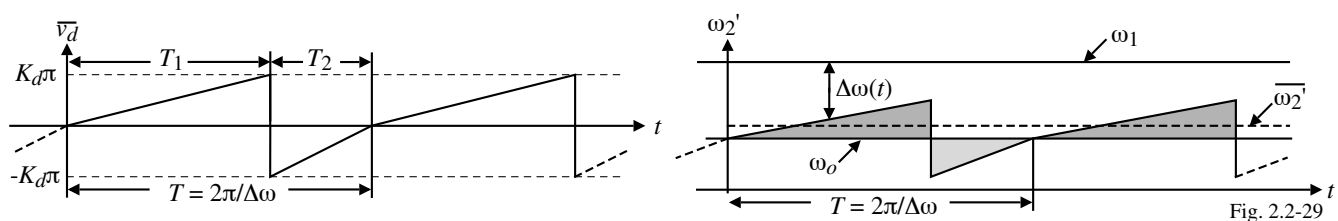

$T_1 > T_2$  because  $\Delta\omega$  is smaller when  $\overline{v_d}$  is positive and larger when  $\overline{v_d}$  is negative.

Results-

Type of Filter	$\Delta\omega_p$ (Low loop gains)	$\Delta\omega_p$ (High loop gains)	Pull-in Time, $T_p$
Passive Lag	$\pi \sqrt{2\xi\omega_n K_o K_d - \omega_n^2}$	$\pi \sqrt{2} \sqrt{\xi\omega_n K_o K_d}$	$\frac{1}{\pi^2} \frac{\Delta\omega_o^2}{\xi\omega_n^2}$
Active Lag	$\pi \sqrt{2\xi\omega_n K_o K_d - \frac{\omega_n^2}{K_a}}$	$\pi \sqrt{2} \sqrt{\xi\omega_n K_o K_d}$	$\frac{1}{\pi^2} \frac{\Delta\omega_o^2}{\xi\omega_n^2}$
Active PI	$\infty$	$\infty$	$\frac{4}{\pi^2} \frac{\Delta\omega_o^2}{\xi\omega_n^2}$

### $\Delta\omega_p$ and $T_p$ for the PFD

Assume that the PFD uses a single power supply of  $V_{DD}$ . The various waveforms are,

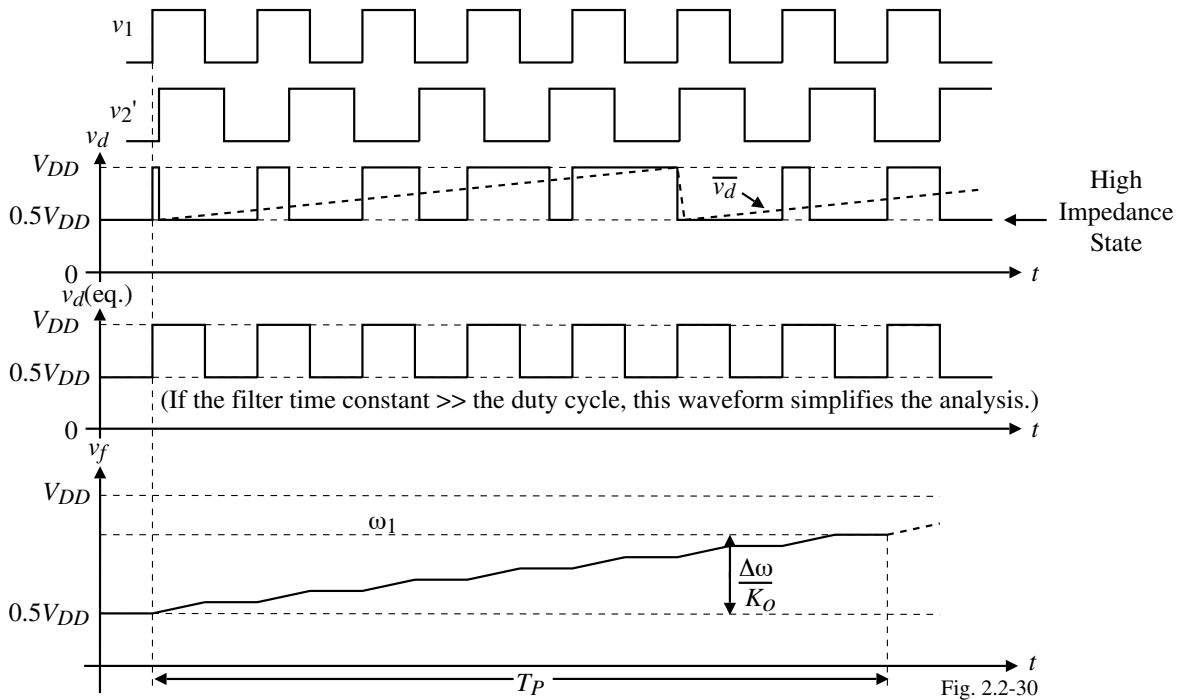

$v_d(eq.)$  is a 50% duty cycle model of the PFD to find  $T_p$ .

### $\Delta\omega_p$ and $T_p$ for the PFD – Continued

Since  $\Delta\omega_p = \infty$ , let us find  $T_p$  using the following model for the passive lag filter:

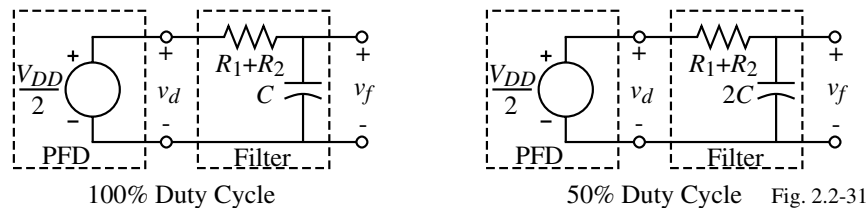

Use the 50% duty cycle model, solve for the time necessary to increase  $v_f$  by  $\Delta\omega/K_o$ .

1.) Loop filter = Passive lag

$$T_p = 2(\tau_1 + \tau_2) \ln \left( \frac{K_o V_{DD}/2}{K_o V_{DD}/2 - \Delta\omega_o} \right)$$

2.) Loop filter = Active lag

$$T_p = 2\tau_1 \ln \left( \frac{K_o K_a V_{DD}/2}{K_o K_a V_{DD}/2 - \Delta\omega_o} \right)$$

3.) Loop filter = Active PI

$$T_p = \frac{2\tau_1 \Delta\omega_o}{K_o V_{DD}/2}$$

For split power supplies, replace  $V_{DD}$  with  $(V_{OH} - V_{OL})$ .

## The Pull-Out Range, $\Delta\omega_{po}$

The pull-out range is the size of the frequency step applied to the reference input that causes the PLL to lose phase tracking.

1.) EXOR:  $\Delta\omega_{po} \approx 2.46\omega_n(\zeta + 0.65)$  for  $0.1 < \zeta < 3$

2.) JK Flip-flop:

$$\left. \begin{aligned} \Delta\omega_{po} &= \pi\omega_n \exp\left[\frac{\zeta}{\sqrt{1-\zeta^2}} \tan^{-1}\left(\frac{\sqrt{1-\zeta^2}}{\zeta}\right)\right], \zeta < 1 \\ \Delta\omega_{po} &= \pi\omega_n e, \zeta = 1 \\ \Delta\omega_{po} &= \pi\omega_n \exp\left[\frac{\zeta}{\sqrt{1-\zeta^2}} \tanh^{-1}\left(\frac{\sqrt{1-\zeta^2}}{\zeta}\right)\right], \zeta > 1 \end{aligned} \right\} \Delta\omega_{po} \approx 5.78\omega_n(\zeta + 0.5) \text{ for all } \zeta$$

3.) PFD:

$$\left. \begin{aligned} \Delta\omega_{po} &= 2\pi\omega_n \exp\left[\frac{\zeta}{\sqrt{1-\zeta^2}} \tan^{-1}\left(\frac{\sqrt{1-\zeta^2}}{\zeta}\right)\right], \zeta < 1 \\ \Delta\omega_{po} &= 2\pi\omega_n e, \zeta = 1 \\ \Delta\omega_{po} &= 2\pi\omega_n \exp\left[\frac{\zeta}{\sqrt{1-\zeta^2}} \tanh^{-1}\left(\frac{\sqrt{1-\zeta^2}}{\zeta}\right)\right], \zeta > 1 \end{aligned} \right\} \Delta\omega_{po} \approx 11.55\omega_n(\zeta + 0.5) \text{ for all } \zeta$$

## Example 1 – A Simple CMOS PLL

Consider the PLL shown. Assume that: 1.) the phase detector is a simple CMOS EXOR whose logic levels are ground and  $V_{DD} = 5V$ , 2.) both the input to the loop and the VCO output are square waves that swing between ground and  $V_{DD}$ , and 3.) that the VCO has a perfectly linear relationship between the control voltage and output frequency of 10 MHz/V. The polarities are such that an increase in control voltage causes an increase in the VCO frequency.

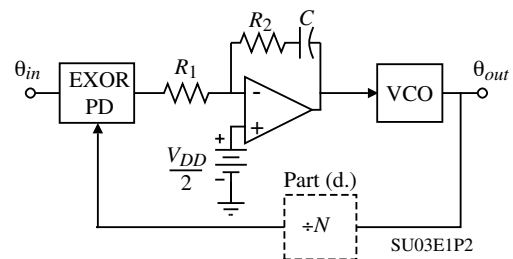

(a.) Derive the expression for the open-loop transmission and the transfer function  $\theta_{out}(s)/\theta_{in}(s)$ .

(b.) Initially assume  $R_2 = 0$  and  $R_1 = 10k\Omega$ . What value of  $C$  gives a loop crossover frequency of 100kHz? What is the phase margin. Assume the op amp is ideal.

(c.) With the value of  $C$  from part (b.), what value of  $R_2$  will provide a phase margin of  $45^\circ$  while preserving a 100 kHz crossover frequency.

(d.) Now assume that a frequency divider of factor  $N$  is inserted into the feedback path. With the component values of part (c.), what is the largest value of  $N$  that can be tolerated without shrinking the phase margin below  $14^\circ$ ?

**Example 1 - Continued****Solution**

$$(a.) \theta_{out}(s) = \frac{K_o}{s} F(s) K_d \left( \theta_{in}(s) + \frac{\theta_{out}(s)}{N} \right) = \frac{5K_o}{s\pi} F(s) \left( \theta_{in}(s) + \frac{\theta_{out}(s)}{N} \right)$$

$$K_d = \frac{5V}{\pi} \quad \text{and} \quad F(s) = -\frac{R_2 + (1/sC)}{sR_1C} = -\frac{sR_2C + 1}{sR_1C} = -\frac{s\tau_2 + 1}{s\tau_1}, \quad \tau_1 = R_1C \quad \text{and} \quad \tau_2 = R_2C$$

$$\therefore \theta_{out}(s) = -\frac{5K_o}{s\pi} \left( \frac{s\tau_2 + 1}{s\tau_1} \right) \left( \theta_{in}(s) + \frac{\theta_{out}(s)}{N} \right)$$

$$\theta_{out}(s) \left[ 1 + \frac{5K_o(s\tau_2 + 1)}{s\pi N} \right] = \frac{5K_o(s\tau_2 + 1)}{s\pi} \theta_{in}(s)$$

$$\frac{\theta_{out}(s)}{\theta_{in}(s)} = \frac{-\frac{5K_o}{\pi\tau_1} (s\tau_2 + 1)}{s^2 + \frac{5K_o}{\pi N} \frac{\tau_2}{\tau_1} s + \frac{5K_o}{\pi N\tau_1}}$$

$$\frac{\theta_{out}(s)}{\theta_{in}(s)} = \frac{-\frac{5K_o}{\pi\tau_1} (s\tau_2 + 1)}{s^2 + \frac{5K_o}{\pi N} \frac{\tau_2}{\tau_1} s + \frac{5K_o}{\pi N\tau_1}} \quad \text{and the loop gain} = LG = -\frac{5K_o(s\tau_2 + 1)}{sN\pi} \left( \frac{s\tau_2 + 1}{s\tau_1} \right)$$

Assume  $N = 1$  to get the answer to part (a.).

**Example 1 - Continued**

(b.) With  $R_2 = 0$ ,  $\tau_2 = 0$  so that the loop gain becomes,

$$LG = -\frac{5K_o}{s^2\tau_1 N\pi} = \frac{5 \cdot 2\pi \times 10^7}{s^2\tau_1\pi} = \frac{10^8}{\omega_c^2\tau_1} = 1 \quad \rightarrow \quad \tau_1 = \frac{10^8}{(2\pi \cdot 10^5)^2} = 253.3 \mu\text{sec.}$$

$$\tau_1 = R_1C \rightarrow 253.3 \mu\text{sec.} = 10\text{k}\Omega C \rightarrow \underline{C = 25.3\text{nF}}$$

The phase margin is  $0^\circ$ .

(c.) The phase margin is totally due to  $\tau_2$ . It is written as,

$$PM = \tan^{-1}(\omega_c\tau_2) = 45^\circ \quad \rightarrow \quad \omega_c\tau_2 = 1 \quad \rightarrow \quad \tau_2 = \frac{1}{\omega_c} = \frac{1}{2\pi \times 10^5} = 1.5915 \mu\text{s} = R_2C$$

$$\therefore R_2 = \frac{1}{2\pi \times 10^5 \times 1.5915 \times 10^{-6}} = \underline{62.83\Omega}$$

(d.)  $N$  does not influence the phase shift so we can write,

$$\tan^{-1}(\omega_c\tau_2) = 14^\circ \rightarrow \omega_c'\tau_2 = 0.2493 \rightarrow \omega_c' = 0.2493\omega_c = 156,657 \text{ rads/sec.}$$

Now the loop gain at  $\omega_c'$  must be unity.

$$LG = -\frac{5K_o}{\omega_c' N\pi} \left( \frac{\sqrt{(\omega_c'\tau_2)^2 + 1}}{\omega_c'\tau_1} \right) = 1 \quad \rightarrow \quad N = \frac{5K_o}{(\omega_c')^2\pi\tau_1} \sqrt{(\omega_c'\tau_2)^2 + 1}$$

$$N = \frac{10^8}{(156,657)^2 \times 253.3 \times 10^{-6} \sqrt{(0.2493)^2 + 1}} = 16.58 = \underline{16}$$

## NOISE PERFORMANCE OF THE DPLL

### Combination of Noise and Information

In the LPLL, the noise and information signals are added because of the linear multiplier PD.

The noise suppression of DPLL's is generally better than LPLL's but no theory of noise exists for the DPLL.

The following pages provide some insight into the noise performance of the DPLL.

### Noise Performance of a DPLL with an EXOR PD

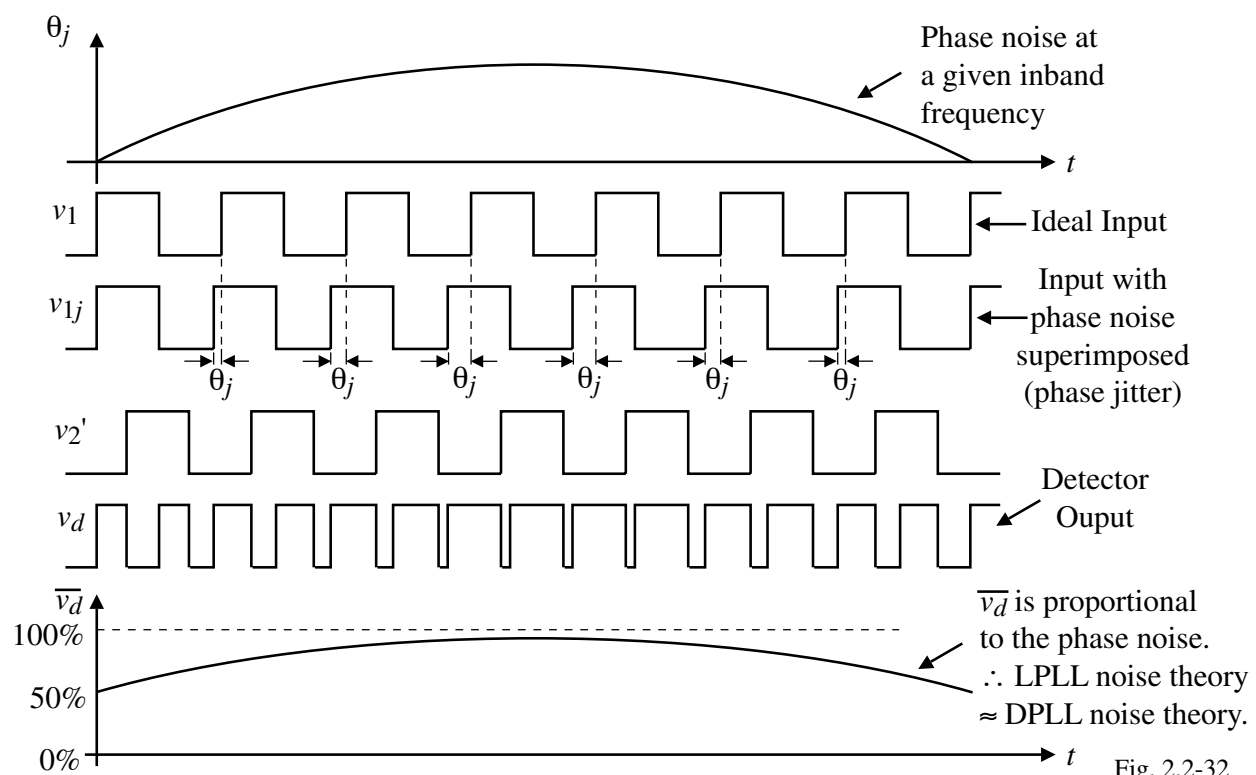
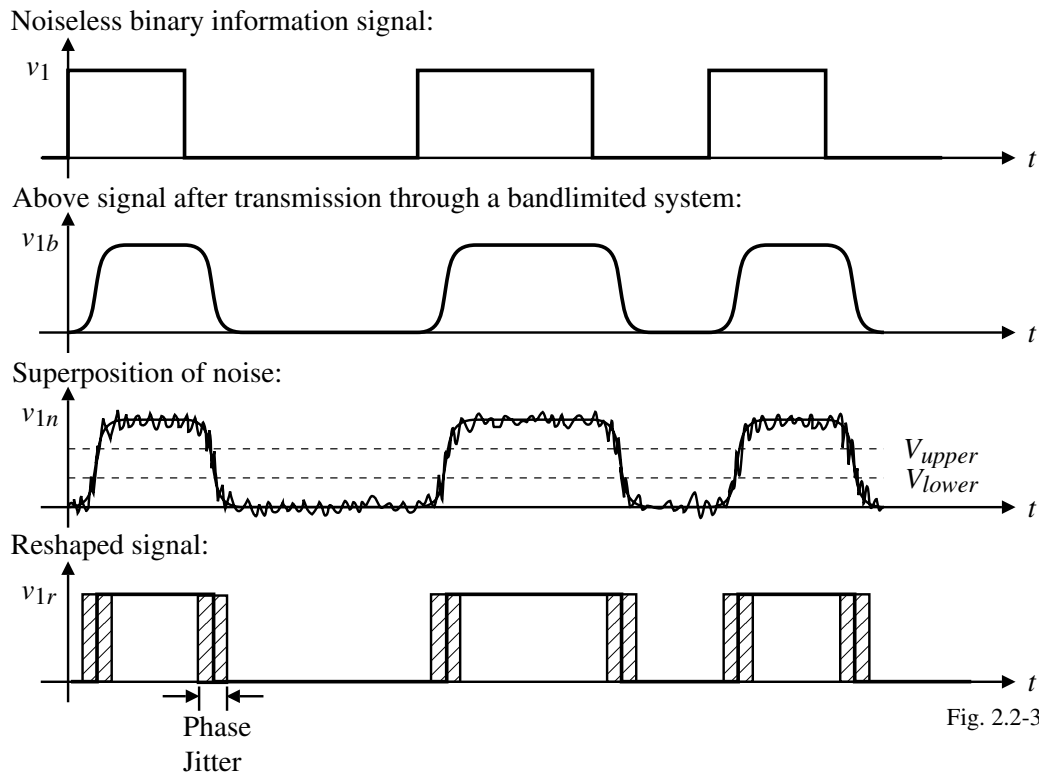

Fig. 2.2-32

## Phase Noise in a Communication Signal

Consider the following simple noise model-



## Input Signal-to-Noise Ratio

The input signal noise ratio of a pulse with phase jitter is defined as,

$$SNR_i = \frac{1}{2 \overline{\theta_{n1}^2}}$$

where

$$\overline{\theta_{n1}^2} \approx \frac{W^2}{36}$$

where,

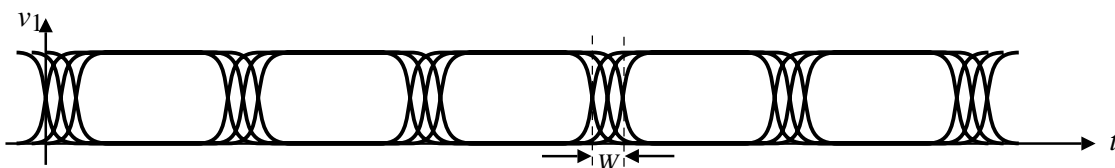

## Phase Noise in a DPLL with a JK Flip-Flop and a PFD

The basic difference is that the JK Flip-flop and PFD are edge-triggered.

When the input signal fades ( $v_1 \rightarrow 0$ ), the reshaped signal can stick at a distinct logic level.

Conclusion:

The noise suppression of the DPLL is about the same for all phase detectors as long as none of the edges of the reference get lost by fading. If fading occurs, the EXOR offers better noise performance.

Summary of DPLL Noise Performance:

$P_s$  = input signal power

$P_n$  = input noise power

$B_i$  = input noise bandwidth

$B_L$  = noise bandwidth  $\approx \frac{\omega_n}{2} \left( \zeta + \frac{1}{4\zeta} \right)$

$SNR_i$  = SNR of the input signal =  $\frac{P_s}{P_n}$

$SNR_L$  = SNR of the loop =  $SNR_i \frac{B_i}{2B_L}$

## DPLL DESIGN PROCEDURE

### Design Procedure

Objective: Design  $K_o$ ,  $K_d$ ,  $\zeta$ , and  $F(s)$

Given: Phase detector and VCO

Steps:

1.) Specify  $f_1(min)$ ,  $f_1(max)$ ,  $f_2(min)$ , and  $f_2(max)$ .

2.) Design  $N$  unless otherwise specified.

Given:  $\omega_n(min) < \omega_n < \omega_n(max)$  and  $\zeta_{min} < \zeta < \zeta_{max}$

For these ranges we get approximately,

$$\frac{\omega_n(max)}{\omega_n(min)} = \sqrt{\frac{N_{max}}{N_{min}}} \quad \text{and} \quad \frac{\zeta_{max}}{\zeta_{min}} = \sqrt{\frac{N_{max}}{N_{min}}} \rightarrow N = N_{mean} = \sqrt{N_{max}N_{min}}$$

3.) Determine  $\zeta$ . Typically,  $\zeta \approx 0.7$ .

4.) If noise is of concern, continue with the next step, otherwise go to step 12.

5.) If there are missing edges in the input signal (fading), go to step 6, otherwise go to step 7.

6.) Choose an EXOR phase detector. Continue with step 8.

$$K_d = \frac{V_{OH} - V_{OL}}{\pi}$$

**Design Procedure – Continued**

7.) Choose the JK Flip-flop or PFD as the phase detector.

$$K_d = \frac{V_{OH} - V_{OL}}{2\pi} \quad (\text{JK flip-flop})$$

$$K_d = \frac{V_{OH} - V_{OL}}{4\pi} \quad (\text{PFD})$$

8.) Specify  $B_L$ .

$B_L$  should be chosen so that  $SNR_i \frac{B_i}{2B_L} \geq 4$

$$\overline{\theta_{n1}^2} \rightarrow SNR_i \quad \text{and} \quad B_i \Rightarrow B_L$$

- If  $N$  changes, this can create a problem because

$$B_L = \frac{\omega_n}{2} \left( \zeta + \frac{1}{4\zeta} \right)$$

and both  $\omega_n$  and  $\zeta$  vary with  $N$ .

- Need to check that  $B_L(\min)$  is large enough.
- If  $B_L$  is too small, then  $N$  should be increased.

**Design Procedure – Continued**

9.) Find  $K_o$ .

$$K_o = \frac{\omega_2(\max) - \omega_2(\min)}{v_f(\max) - v_f(\min)}$$

10.) Find  $\omega_n$  given  $B_L$  and  $\zeta$ .

$$\omega_n = \frac{8B_L\zeta}{1+4\zeta}$$

If  $N$  is variable, use  $B_L$  and  $\zeta$  correspondingly to  $N = N_{mean}$ .

11.) Specify the loop filter.

Given  $\omega_n$ ,  $\zeta$ ,  $K_o$ ,  $K_d$ , and  $N$  find  $\tau_1$ ,  $\tau_2$ , and  $K_a$  ( $K_a > 1$ ).

Go to step 19.

12.) Continued from step 4.

Choose the PFD  $\rightarrow K_d = \frac{V_{OH} - V_{OL}}{4\pi}$

13.) Find  $K_o$ .

$$K_o = \frac{\omega_2(\max) - \omega_2(\min)}{v_f(\max) - v_f(\min)}$$

**Design Procedure – Continued**

14.) Specify the type of loop filter. Use the passive lag filter as the others offer no benefits.

15.) Determine  $\omega_n$ .

a.) Fast switching ( $T_p$ ). Go to step 16.

b.) DPLL does not lock out when switching from  $N_{dref}$  to  $(N_o+1)f_{ref}$ .  $\therefore \Delta\omega_{po} < f_{ref}$ .

Go to step 20.

c.) Neither the pull-in time nor the pull-out range are critical. Go to step 21.

16.) Given the maximum  $T_p$  allowed for the largest frequency step, solve for  $\tau_1$  or  $\tau_1+\tau_2$ .

17.) Find  $\omega_n$ .

Loop filter is passive: 
$$\omega_n = \sqrt{\frac{K_o K_d}{N(\tau_1 + \tau_2)}}$$

Active lag filter: 
$$\omega_n = \sqrt{\frac{K_o K_d K_a}{N\tau_1}}$$

Active PI filter: 
$$\omega_n = \sqrt{\frac{K_o K_d}{N\tau_1}}$$

**Design Procedure – Continued**

18.) Given  $\omega_n$  and  $\zeta$ , find  $\tau_2$ .

$$\tau_2 = \frac{2\zeta}{\omega_n}$$

If the system cannot be realized (negative values of  $\tau_1$  or  $\tau_2$ ), modify  $\omega_n$  and  $\zeta$  appropriately.

19.) Given  $\tau_1$  and  $\tau_2$  (and  $K_a$ ), determine the filter components.

20.) Given  $\Delta\omega_{po}$  and  $\zeta$ , find  $\omega_n$ .

$$\omega_n \approx \frac{\Delta\omega_{po}}{11.55(\zeta+0.5)}$$

21.) Given  $T_L$ , find  $\omega_n$  from  $\omega_n \approx 2\pi/T_L$ .

22.) Given  $\omega_n$ , find  $\tau_1$  and  $\tau_1+\tau_2$ .

Passive lag filter: 
$$\tau_1 + \tau_2 = \frac{K_o K_d}{N\omega_n^2}$$

Active lag filter: 
$$\tau_1 = \frac{K_o K_d K_a}{N\omega_n^2}$$

Active PI filter: 
$$\tau_1 = \frac{K_o K_d}{N\omega_n^2}$$

Go to step 18.).

## Flowchart of the DPLL Design Procedure

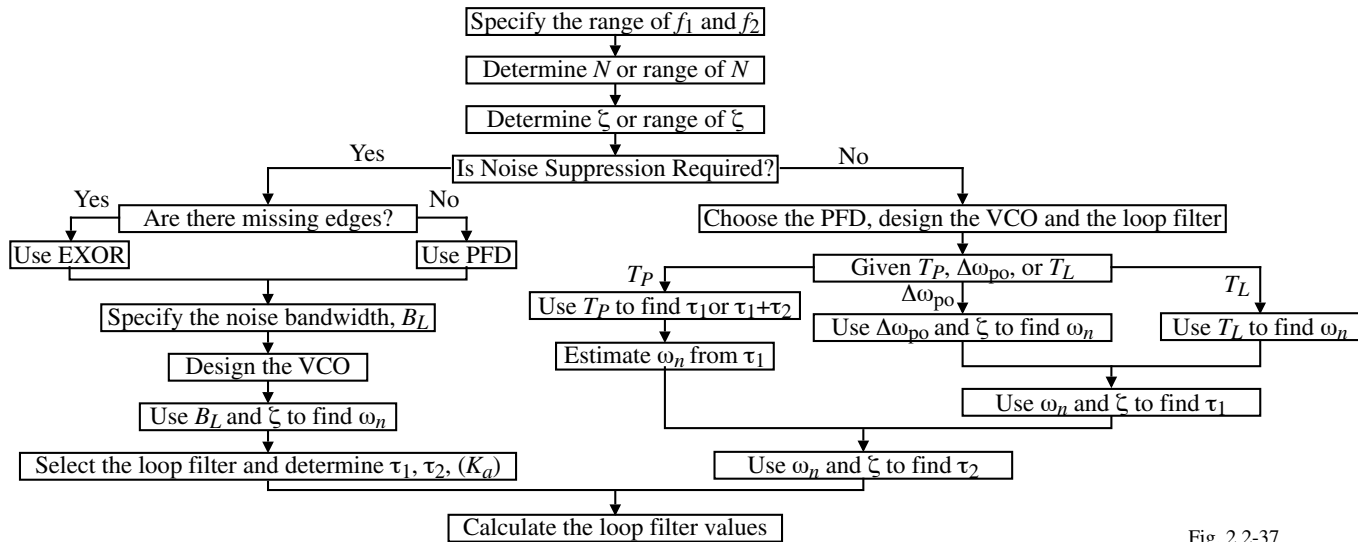

Fig. 2.2-37

### Design Example – A Frequency Synthesizer Using the 74HC/HCT4076

Design a DPLL frequency synthesizer using the CMOS 74HC/HCT4076 PLL. The frequency synthesizer should be able to produce a set of frequencies in the range of 1MHz to 2MHz with a channel spacing of 10kHz. Use a PFD and a passive lag-lead filter.

Design:

- 1.) Determine the ranges of the input and output frequencies.

$$f_1 \text{ is constant at } 10\text{kHz. } f_2(\text{min}) = 1\text{MHz and } f_2(\text{max}) = 2\text{MHz}$$

- 2.) Choose  $N$ .

$$N_{\text{max}} = \frac{2\text{MHz}}{10\text{kHz}} = 200 \quad \text{and} \quad N_{\text{min}} = \frac{1\text{MHz}}{10\text{kHz}} = 100$$

$$\therefore N_{\text{mean}} = \sqrt{N_{\text{max}} \cdot N_{\text{min}}} = 141$$

- 3.) Find  $\zeta$ . Start by choosing  $\zeta = 0.7$  and find  $\zeta_{\text{max}}$  and  $\zeta_{\text{min}}$ .

$$\frac{\zeta_{\text{max}}}{\zeta_{\text{min}}} = \sqrt{\frac{N_{\text{max}}}{N_{\text{min}}}} = \sqrt{2} \quad \text{and} \quad \zeta = \sqrt{\zeta_{\text{max}} \cdot \zeta_{\text{min}}} = 0.7$$

$$\therefore \zeta_{\text{min}}^2 \sqrt{2} = 0.49 \quad \rightarrow \quad \zeta_{\text{min}} = 0.59 \quad \text{and} \quad \zeta_{\text{max}} = 0.59 \sqrt{2} = 0.83$$

$$\therefore 0.59 < \zeta < 0.83 \quad \text{which is consistent with our choice of } \zeta.$$

- 4.) Select the PFD as the phase detector. For the 74HC/HCT4076,  $V_{OH} = 5\text{V}$  and  $V_{OL} = 0\text{V}$ . This gives a  $K_d = 5\text{V}/4\pi = 0.4 \text{ V/rad}$ .

## Design Example – Continued

5.) According to the data sheet of the 74HC4046A, the VCO operates linearly in the voltage range of  $v_f = 1.1\text{V}$  to  $3.9\text{V}$  as shown.

$$\therefore K_o = \frac{2 \times 10^6 \times 2\pi}{3.9 - 1.1} = 2.2 \times 10^6 \text{ rads/V} \cdot \text{sec}$$

The data sheet also requires calculation of two resistors,  $R_1$  and  $R_2$ , and a capacitor,  $C_1$ .

Using the graphs from the data sheet gives,

$$R_1 = 47\text{k}\Omega, R_2 = 130\text{k}\Omega, \text{ and } C_1 = 100\text{pF}.$$

6.) Assume the loop should lock with 1ms.

$$\therefore T_L = 1\text{ms} \rightarrow \omega_n = 2\pi/T_L = 6280 \text{ rads/sec.}$$

7.) Using a passive loop filter we get,

$$\tau_1 + \tau_2 = \frac{K_o K_d}{N \omega_n^2} = \frac{2.2 \times 10^6 \cdot 0.4}{141 \cdot 6280^2} = 161 \mu\text{s}$$

8.)  $\tau_2 = \frac{2\zeta}{\omega_n} = \frac{2 \cdot 0.7}{6280} = 223 \mu\text{s} !!!$  (The problem is that  $\tau_1 + \tau_2$  is too small)

Go back and choose  $T_L = 2\text{ms} \rightarrow \omega_n = 2\pi/T_L = 3140 \text{ rads/sec.}$

$$\tau_1 + \tau_2 = \frac{K_o K_d}{N \omega_n^2} = \frac{2.2 \times 10^6 \cdot 0.4}{141 \cdot 3140^2} = 633 \mu\text{s} \text{ and } \tau_2 = \frac{2\zeta}{\omega_n} = \frac{2 \cdot 0.7}{3140} = 446 \mu\text{s} \rightarrow \tau_1 = 187 \mu\text{s}$$

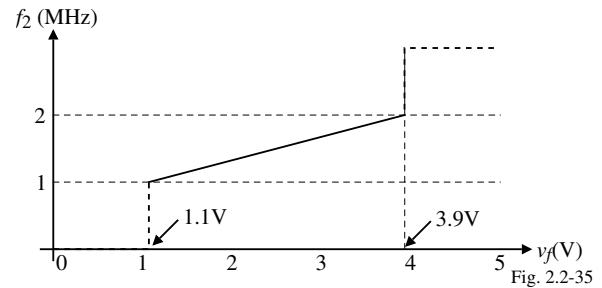

Fig. 2.2-35

## Design Problem – Continued

9.) Design the loop filter.

For optimum sideband suppression,  $C$  should be large. Choose  $C = 0.33 \mu\text{F}$ .

$$\therefore R_1 = \frac{\tau_1}{C} = \frac{187 \times 10^{-6}}{0.33 \times 10^{-6}} = 567 \Omega \text{ and } R_2 = \frac{\tau_2}{C} = \frac{446 \times 10^{-6}}{0.33 \times 10^{-6}} = 1.351 \text{ k}\Omega$$

The data sheet requires that  $R_1 + R_2 \geq 470 \Omega$  which is satisfied.

Block diagram of the DPLL frequency synthesizer design of this example:

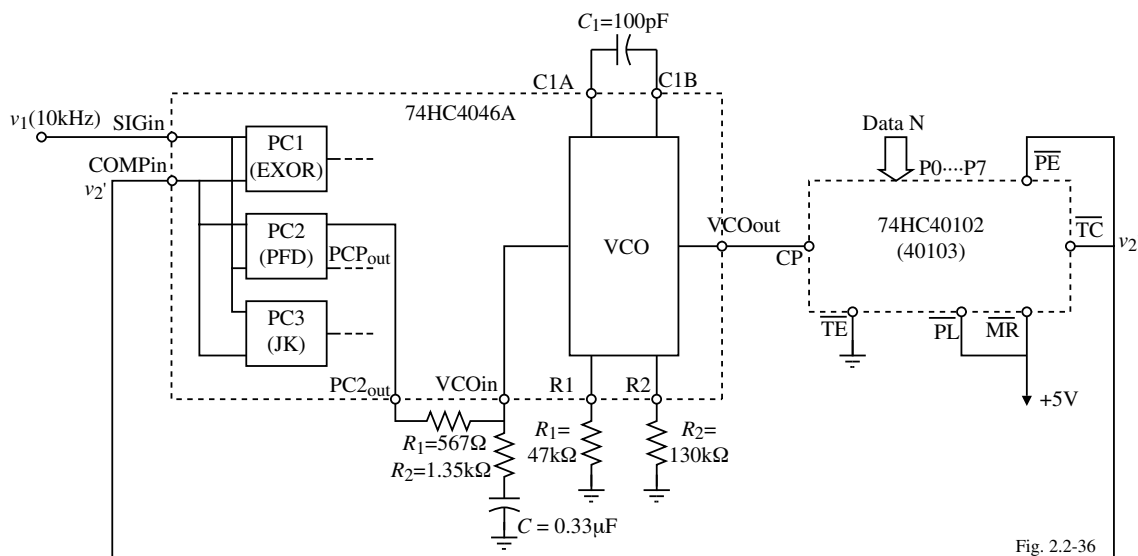
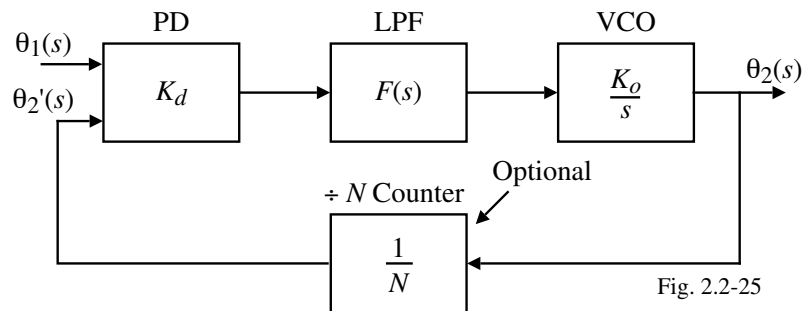

Fig. 2.2-36

## Simulation of the DPLL Example

The block diagram of this example is shown below.



The PFD-charge pump combination can be approximated as<sup>†</sup>

$$"K_d F(s)" = \frac{K_d(1+s\tau_2)}{s(\tau_1+\tau_2)}$$

Therefore, the loop gain becomes

$$LG(s) = \frac{K_o K_d (1+s\tau_2)}{s^2(\tau_1+\tau_2)} = \frac{K_v (1+s\tau_2)}{(s+\varepsilon)^2(\tau_1+\tau_2)} \quad (\text{the factor } \varepsilon \text{ is used for simulation purposes})$$

For this problem,

$$K_d = 0.4\text{V/rad.}, K_o = 2.2 \times 10^6, \tau_2 = 446\mu\text{s}, \text{ and } \tau_1 + \tau_2 = 633\mu\text{s}. \text{ Also choose } \varepsilon = 0.01.$$

<sup>†</sup> R.E. Best, "Phase-Locked Loops – Design, Simulation, and Applications," 4<sup>th</sup> Ed., McGraw-Hill, NY, p. 103

## Simulation of the DPLL Example – Continued

### PSPIICE Input File

```
DPLL Design Problem-Open Loop Response - Best
VS 1 0 AC 1.0
R1 1 0 10K
* Loop bandwidth = Kv = 8.8x10E5 sec.-1   Tau1=187E-6   Tau2=446E-6   N=141
ELPLL 2 0 LAPLACE {V(1)} = {8.8E+6/(S+0.01)/141*(0.446E-3*S+1)/(S+0.01)/0.633E-3}
R2 2 0 10K
*Steady state AC analysis
.AC DEC 20 10 100K
.PRINT AC VDB(2) VP(2)
.PROBE
.END
```

### Simulation Results:

Note that the phase is very close to 0° and  $|LG| \gg 1$  at low frequencies which is typical of type II systems.

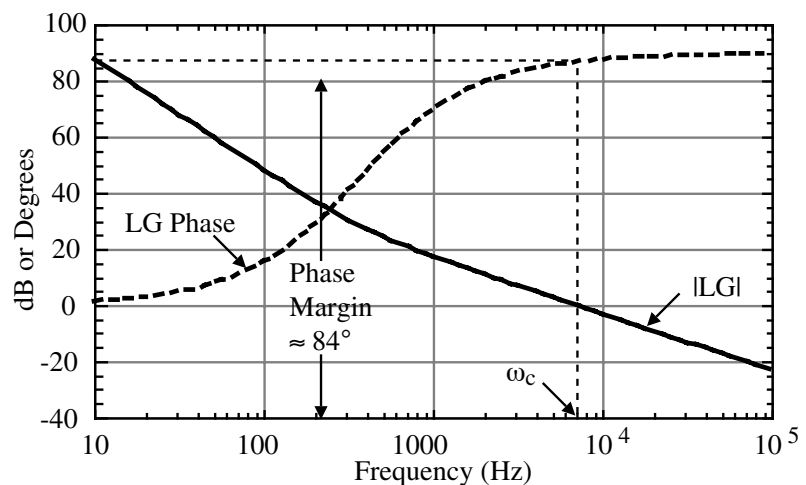

## DPLL SYSTEM SIMULATION

### Examples of Case Studies using the Best Software<sup>†</sup>

#### PLL Parameters-

Supply voltages:

Positive supply = 5V      Negative supply = -5V

Phase detector:

$V_{sat}^+ = 4.5V$        $V_{sat}^- = 0.5V$

Loop filter:

$\tau_1 = 500\mu s$        $\tau_2 = 50\mu s$

Oscillator:

$K_o = 130,000 \text{ rads/V}\cdot\text{sec}$        $V_{sat}^+ = 4.5V$        $V_{sat}^- = 0.5V$

The simulation program will be used to verify the following calculated values:

$\omega_n = 17,347 \text{ rads/sec.}$

$\zeta = 0.486$

$\Delta f_{po} = 7719 \text{ Hz}$

$\Delta f_p = 13,192 \text{ Hz}$

<sup>†</sup> Roland E. Best, Phase-Locked Loops – Design, Simulation, and Applications, 4<sup>th</sup> ed., McGraw-Hill Book Co., 1999, New York, NY

### Case 1 – System Benchmark

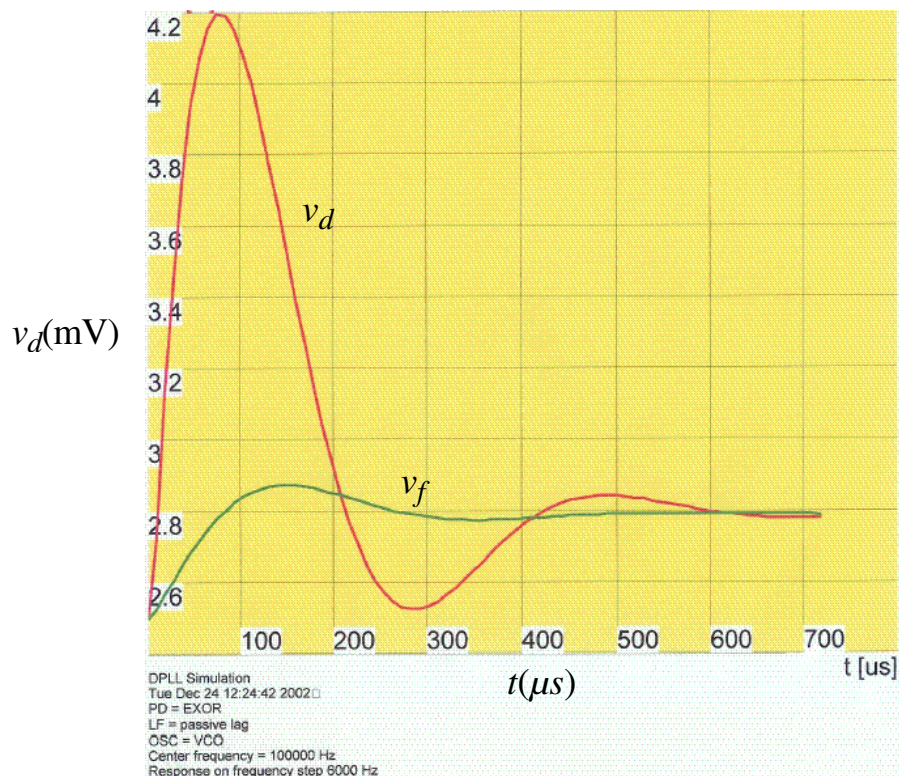

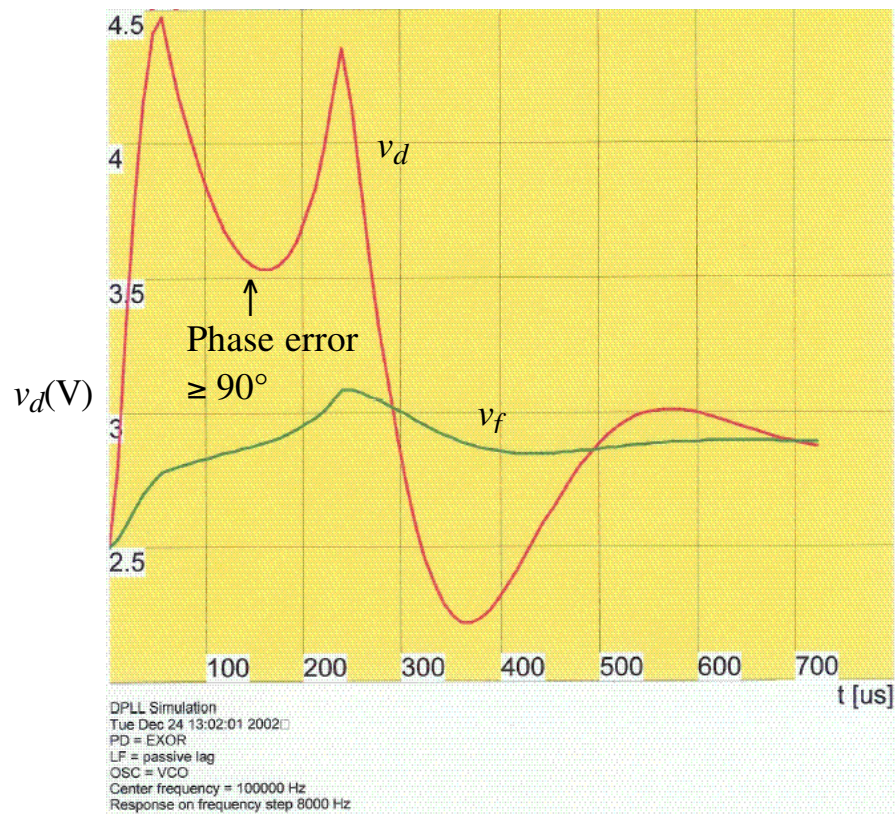
**Case 2 -  $\Delta f = 8000\text{Hz}$** 

CMOS Phase Locked Loops

© P.E. Allen - 2003

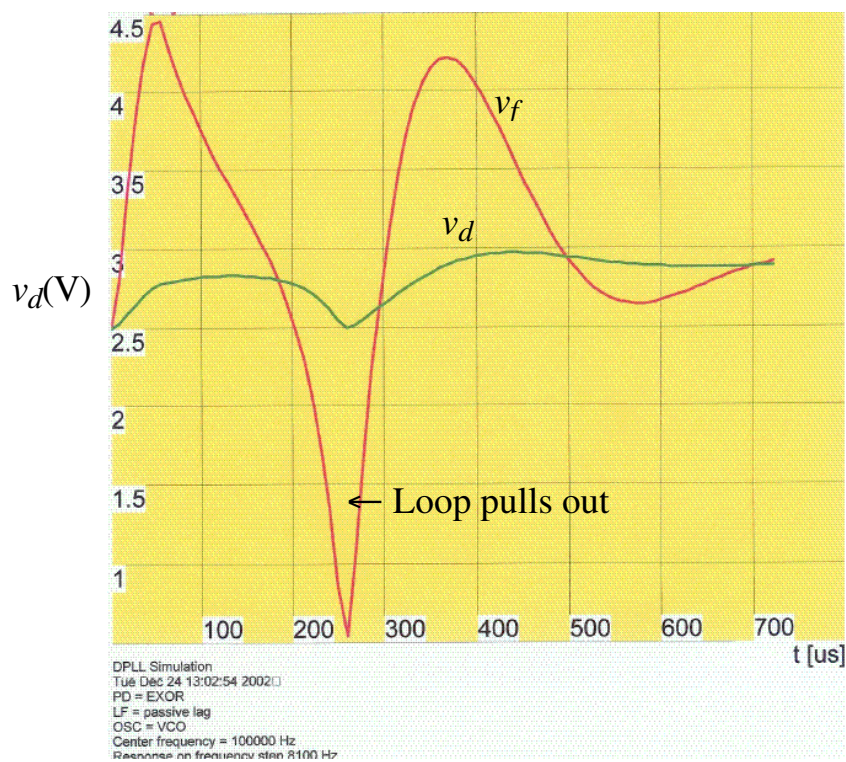
**Case 3 – Loop Just Locks Out**

CMOS Phase Locked Loops

© P.E. Allen - 2003

### Case 4 – Pull-In Range Verification

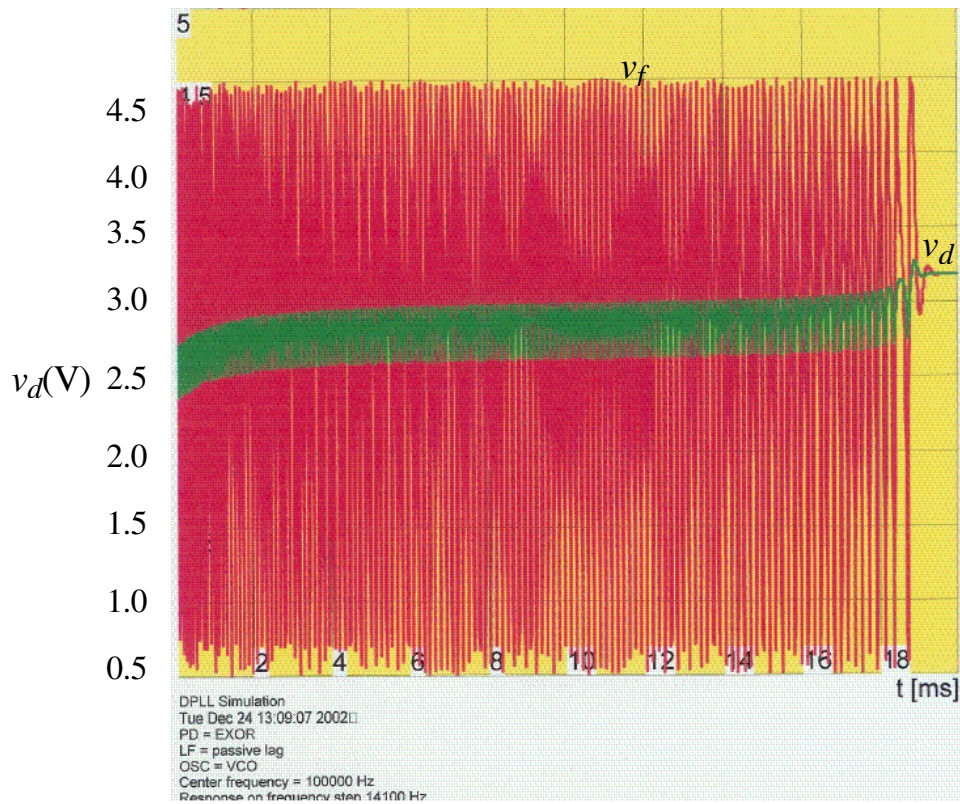

Loop will not pull back in for  $df > 14,200$  Hz

### Case 5 – PFD and Illustration of a Virtually Infinite Pull-In Range

$\Delta f_p = \pm 40\text{kHz}$

$\Delta f = 35$  kHz to avoid clipping of  $v_f$ .

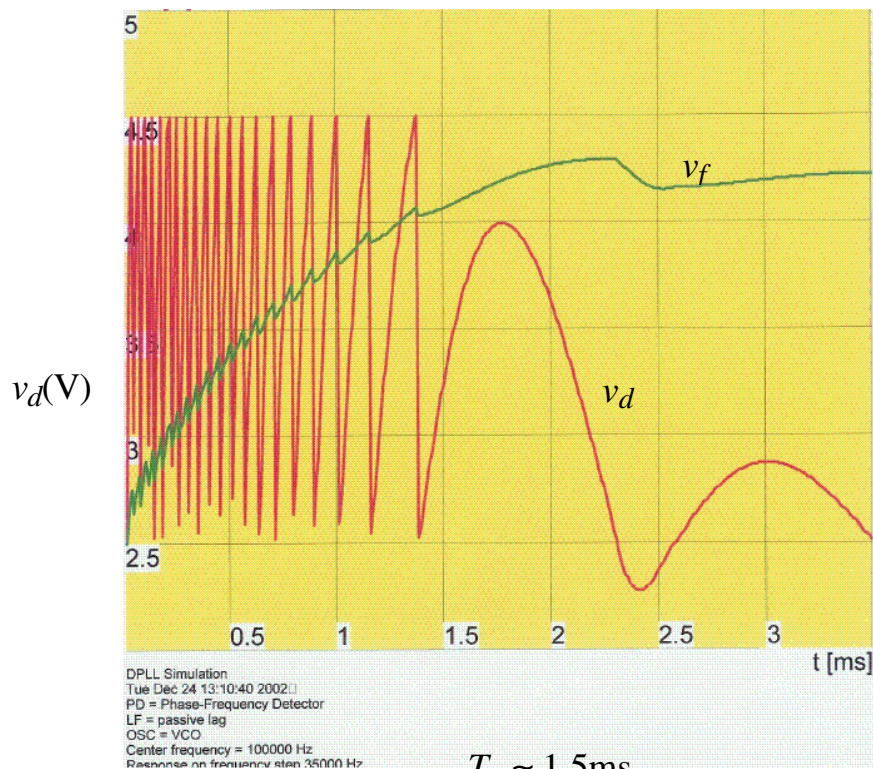

$T_p \approx 1.5\text{ms}$

## Case 6 – EXOR with Active PI Filter

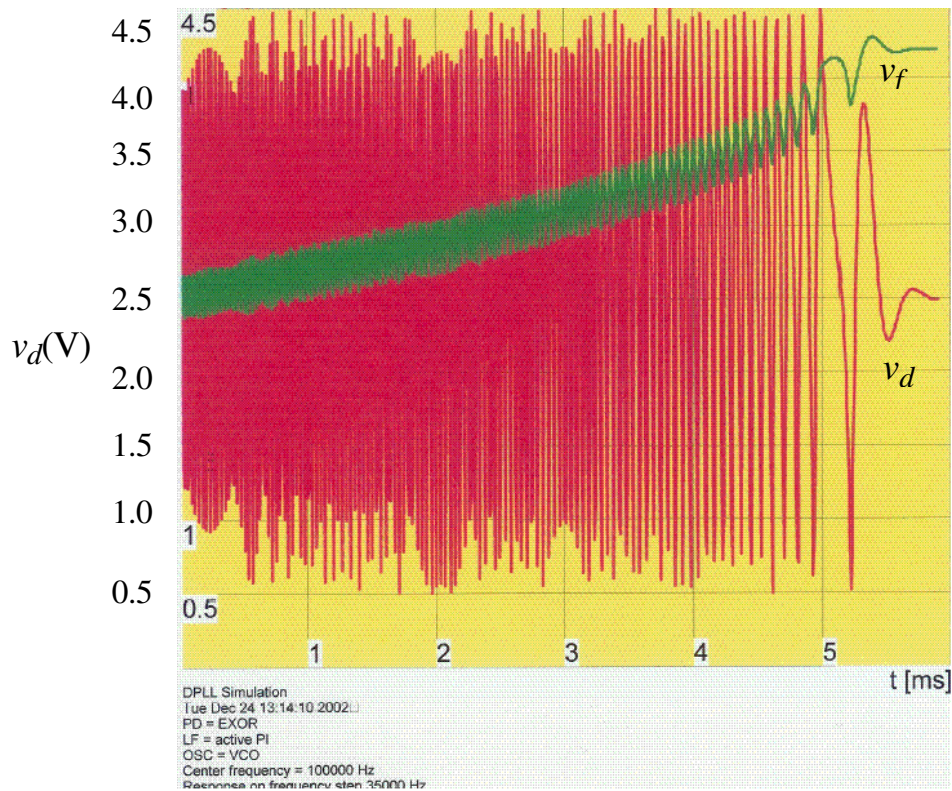

$$T_p \approx 5\text{ms}$$

## SUMMARY

- The DPLL has a digital phase detector and the remainder of the blocks are analog
- Digital phase detectors
  - EXOR Gate
  - JK Flip-Flop
  - Phase-Frequency Detector
- Charge pump – a filter implementation using current sources and a capacitor that works with the PFD
- Charge pumps implement a pole at the origin to result in zero phase error
- The DPLL is much more compatible with IC technology and is the primary form of PLL used for frequency synthesizers